



**Owner
and
Operator Manual**

**MEGA NEV & Utility
Electric Vehicles**

**Van
Dropside
TiltBed
Cargo
Refuse**



712112-05

PREFACE

Welcome, and congratulations on your choice of the Columbia Electric Vehicle from Columbia ParCar Corp.!

Vehicle with a 13 digit VIN are off road use as Personal Transport Vehicles (PTV). Vehicles with a 17 digit VIN are on road use as Low Speed Vehicle (LSV) also known as Neighborhood Electric Vehicles (NEV's). These vehicles meet the requirements of the National Highway Traffic & Safety Administration (NHTSA) as stated in the Code of Federal Regulations, Title 49, Part 571, Standard 500, Low Speed Vehicles.

Some of the equipment in this manual may not apply to your vehicle, depending on which model you have.

To the best knowledge of Columbia ParCar Corp., the material contained herein is accurate as of the date this publication was approved for printing. Columbia Par-Car Corp. is not liable for errors in this manual or for incidental or consequential damages that result from the use of the material in this manual. Columbia ParCar Corp. reserves the right to change specifications, equipment or designs at any time without notice and without incurring obligation.

This manual contains proprietary information that is protected by copyright. All rights are reserved. No part of this manual may be photocopied, reproduced, or translated to another language without the written consent of Columbia ParCar Corp.

Columbia ParCar Corp. products are manufactured under one or more of the following U.S. Patents - 2986162, 2987934, 3116089, 3144631, 3144860, 3229792, 3434887, 3559773, 3673359, 3680403, 3683716, 3709317, 4648473, Des. 225626.



A member of the Nordic Group of Companies
1115 Commercial Avenue, Reedsburg, WI 53959
Phone - 608.524.8888 Fax - 608.524.8380
www.parcar.com

TABLE OF CONTENTS

1.0 GENERAL INFORMATION

- 1.1 SAFETY MESSAGES
- 1.2 SPECIFICATIONS
- 1.3 VEHICLE IDENTIFICATION NUMBER (VIN)
- 1.4 VIN MATRIX Utility)
- 1.5 VIN MATRIX (NEV)

2.0 SAFETY

- 2.1 GETTING STARTED
- 2.2 VEHICLE SAFETY
- 2.3 OPERATION SAFETY
- 2.4 CHILD SAFETY
- 2.5 CONCERNS

3.0 OPERATION

- 3.1 IMPORTANT FIRST STEP
- 3.2 INSPECTING THE VEHICLE
- 3.3 SEATS AND SEAT BELTS
- 3.4 FRONT DOORS
- 3.5 HEATER
- 3.6 HAZARD WARNING FLASHER
- 3.7 INSTRUMENT PANEL
- 3.8 WINDSHIELD WIPER
- 3.9 LIGHTS, HORN & TURN SIGNALS
- 3.10 INTERIOR LIGHT
- 3.11 12V POWER OUTLET
- 3.12 MULTIFUNCTIONAL DISPLAY INDICATOR (MDI)
- 3.13 WINDSHIELD DEFROST SWITCH
- 3.14 KEYSWITCH
- 3.15 DIRECTIONAL KNOB
- 3.16 HANDBRAKE
- 3.17 CHARGER RECEPTACLE & REMOTE LED

4.0 DRIVING THE VEHICLE

- 4.1 PRE-OPERATION CHECKLIST
- 4.2 STARTING AND STOPPING
- 4.3 BATTERIES
- 4.4 RECOMMENDED BREAK-IN PERIOD
- 4.5 TILTBED/REFUSE LOADING
- 4.6 TILTBED/REFUSE, RAISING AND LOWERING

5.0 ELECTRICAL

- 5.1 IMPORTANT INFORMATION
- 5.2 FUSE BOX – 48V CIRCUIT
- 5.3 FUSE BOX – 12V CIRCUIT
- 5.4 BATTERY MAINTENANCE
- 5.5 BATTERY CLEANING
- 5.6 CONDITIONS WHICH AFFECT CHARGING
- 5.7 DELTA-Q BATTERY CHARGING
 - 5.7.1 CHARGER OPERATION
 - 5.7.2 RED LIGHT CHARGER ERROR CODES
 - 5.7.3 CHECK/CHANGE CHARGING ALGORITHM
- 5.8 EXCESSIVELY DISCHARGED BATTERIES
- 5.9 SPECIFIC GRAVITY TEST
- 5.10 TIPS FOR PROLONGING BATTERY LIFE
- 5.12 SINGLE POINT WATERING SYSTEM

6.0 SERVICING YOUR VEHICLE

- 6.1 MAINTENANCE GUIDELINES
- 6.2 TILT BED SAFETY
- 6.3 REFUSE SAFETY
- 6.4 CLEANING
- 6.5 MAINTENANCE INDICATOR
- 6.6 MAINTENANCE SCHEDULE – OWNER/OPERATOR
- 6.7 MAINTENANCE SCHEDULE – QUALIFIED TECHNICIAN
- 6.8 SPARE TIRE
- 6.9 TIRE PRESSURE
- 6.10 REPLACING BULBS
- 6.11 CHECKING BRAKE FLUID LEVEL
- 6.12 WINDSHIELD WASHER FLUID
- 6.13 TILT MECHANISM
- 6.14 TRAILERING THE VEHICLE
- 6.15 VEHICLE STORAGE
- 6.16 VEHICLE TROUBLESHOOTING

NOTICE: In an effort to streamline product support, please ensure your vehicle is properly registered with Columbia ParCar. Registration allows for more effective product support including product updates and warranty processing. Please consult with your servicing dealer to verify or complete the registration process.

CHANGE HISTORY		
DATE	DESCRIPTION	BY
8/08	Issued	TS
8/12	Added Delta Q remote LED and update	TS
4/13	Up-dated heater picture and maintenance section.	TS
11/12/13	Corrected algorithm table.	TS

1.0 GENERAL INFORMATION

This manual provides important safety information, operating instructions, model specifications and maintenance instructions for the vehicle.

The information in this manual is limited to care and maintenance information only. Information covering repairs and technical service is provided in detailed service manuals available from Columbia Dealers. These activities require the attention of skilled technicians and the use of special tools and equipment. Your Columbia Dealer has the facilities, experience and genuine Columbia vehicle parts and accessories to properly service Columbia vehicles.

1.1 SAFETY MESSAGES

Safety messages and other information in this manual are preceded by the words **DANGER**, **WARNING**, **CAUTION** or **NOTICE**. They are printed in bold face and are very important. We recommend you take special notice of this information.

⚠ DANGER
Danger indicates a hazardous situation which, if not avoided, will result in death or serious injury.
⚠ WARNING
Warning indicates a hazardous situation which, if not avoided, could result in death or serious injury.
⚠ CAUTION
Caution indicates a hazardous situation which, if not avoided, could result in minor or moderate injury.
NOTICE: Notices are messages not related to personal injury. They will provide key information to prevent property damage and to assure procedures are more easily understood or implemented.

1.2 SPECIFICATIONS

	Van	DropSide	TiltBed	Cargo	Refuse
Overall Length (in.)	129				
Overall Width* (in.)	60	60.2		58.7	60.2
Overall Height (in.)	73	70.9			72.1
Wheel Base (in.)	91				
Ground Clearance (in.)	7				
Weight (lbs.)	1573	1562	1646	1452	1782
Rated Capacity (lbs.)	1177	1188	1104	1298	650

* Excluding mirrors

All Models	
Passenger Capacity	2
Maximum Rated Speed	up to 25 MPH
Range-Standard Battery Group	Up to 40 miles**
Turning Radius	19 feet
Traction Power System	48 Volt
Motor	5 KW AC
Speed Control	Solid state, regenerative braking
Charger	110-240 VAC, 50/60 Hz
Drive	Front wheel, direct
Steering	Rack & Pinion
Hydraulic Brakes-Front/Rear	Disc/Drum
Independent Suspension-Front	McPherson strut/Coil
Independent Suspension-Rear	Coil/Shock
Tires	145/70R13. Recommend 29 psi.
Chassis	Aluminum construction

** Range will vary depending upon load, temperature, terrain and driving style.

1.3 VEHICLE IDENTIFICATION NUMBER (VIN)

⚠ CAUTION
Do not remove any nameplate, warnings, or instructions affixed to the Columbia vehicle. Promptly replace any that become damaged or removed.

Each vehicle is assigned a unique Vehicle Identification Number (VIN).

The VIN describes facts and features of the vehicle and contains 17 digits (LSV) or 13 digits (PTV).

The VIN can be found in four locations: on the top section of the dash, under the steering wheel cover (Figure 1.3), in the glove box and below the drive seat.

Record the VIN here and provide this number to the dealer when repairs or adjustments are required.



Figure 1.3

VIN _____

1.4 VIN MATRIX – Personal Transport Vehicle

Digit 1 thru 3: Model Group	MGA = Utility, MGD = DropSide MGV = Van Bed	MGC = Cargo Bed, MGT = TiltBed,
Digit 4: Power System	E = Separately Excited Regen/ACE+ System G = AC Drive Induction	
Digit 5: System Voltage/Batteries	4 = 48V (8-6V) G = 48V GEL (8-6V),	M = 48V AGM (8-6V)
Digit 6: Standard or Special Product	- = Standard Product * = Special Product	
Digit 7: Controller Amperage	4 = 400 Amp 5 = 500 Amp	
Digit 8: Axle Brake System	N = Front Wheel Drive: F & R Hydraulic	
Digit 9: Model Year	L = 2012, M = 2013, N = 2014 etc.	
Digit 10-13: Build Sequence	0000 - 9999	

1.5 VIN MATRIX- Low Speed Vehicle

Digit 1 thru 3: Manufacturer Identification	5FC = CPC	
Digit 4: Line	L = Low Speed Vehicle	
Digit 5: Series	M = MEGA	
Digit 6: Body Type	2 = 2 Person 4 = 4 Person	3 = Long Bed 5 = Short Bed
Digit 7: Engine Type	6 = Separately Excited 48V ACE+ System 8 = 48V AC Induction Drive	
Digit 8: Restraint	A = Type 1 Seat Belt Assembly B = Type 2 Seat Belt Assembly (3 Point)	
Digit 9: Check Digit	Calculated per IAW 49CFR 565.4	
Digit 10: Model Year	C = 2012, D = 2013. E = 2014	
Digit 11: Plant Location	1 = Reedsburg	
Digit 12-17: Sequential Numbers	00019 - 000999	

⚠ WARNING

Vehicles with a 13 digit VIN are not Federal or State DOT approved and is not equipped to be operated on public roads or highways.

Vehicle with a 17 digit VIN are Federal or State DOT approved and are equipped to be operated on public roads or highways.

2.0 SAFETY

2.1 GETTING STARTED

For personal safety before operating the vehicle, it is the operator's responsibility to read, understand and follow the basic rules of operation and maintenance instructions in this manual. If you are responsible for the use of the vehicle, it is your responsibility to inform the person or persons using the vehicle about the following basic rules of operation for their personal safety.

It is Columbia ParCar Corporation's specific recommendation that the following warnings must be observed at all times. Not all are repeated throughout this manual, but the recommendations included must be observed whenever these subjects (operator safety, battery hazards, etc.) are encountered. Section 4.0 ELECTRIC SYSTEM contains important safety and other system information.

2.2 VEHICLE SAFETY

⚠ DANGER

Any modifications or changes to the vehicle that affect the stability, steering or that results in increased speed beyond factory specifications could result in vehicle damage, severe personal injury or death.

⚠ WARNING

Only trained service professionals should repair or service this vehicle. Persons doing even simple repairs or maintenance should have a working knowledge and experience in general electrical and mechanical repair.

Follow all procedures exactly and observe all safety messages stated in this manual. Working on vehicles without following proper procedures and using proper equipment may result in vehicle damage or personal injury.

Moving parts hazard! When operating any vehicle in a stationary position, avoid components which could snag clothing or cause severe injury to body parts. A running vehicle must be worked on with the greatest care.

If any problems are found during scheduled maintenance or inspections, do not operate vehicle until repairs are made.

Always wear safety glasses or approved eye protection when performing vehicle maintenance.

⚠ CAUTION

When replacement parts are required, use only genuine Columbia vehicle parts. No modifications or additions, which affect the mechanical or electrical integrity and the safe operation of the vehicle, shall be made without the written approval of the manufacturer.

If such modifications are approved, the capacity, operation, and maintenance instruction markings shall be changed accordingly. If in doubt about any modification, contact your local Columbia Dealer or Columbia ParCar Corp. Customer Service.

Do not overload the vehicle. Never exceed rated capacity as specified on the vehicle nameplate.

Failure to maintain vehicle properly or make necessary repairs could result in decreased vehicle performance, reliability or cause severe personal injury.

Your safety and the safety of others depend on your safe operation and maintenance of this vehicle. Prior to operation, you, the operator, must be thoroughly familiar with this and all other sections of this manual.

2.3 OPERATION SAFETY

For personal safety and to maintain stability and control, operate this vehicle under these conditions only. Failure to comply with these warnings may result in bodily injury and property damage.

⚠ WARNING

Do not drive this vehicle unless you are a qualified and trained operator and familiar with the vehicle operational controls.

All vehicles should be operated from the driver's side.

Never exceed the capacity ratings of the vehicle. Exceeding these limits may endanger occupants.

Personal injury may result if body parts (arms, head and legs) are not kept inside vehicle while moving. Do not start moving until all occupants are seated with seat belts fastened, if equipped. Remain seated and hold on while vehicle is in motion.

Before leaving your seat, completely stop vehicle and lock parking brake. If vehicle is to be left unattended, turn keyswitch to OFF and remove the key.

⚠ WARNING

Do not use accelerator to hold vehicle on an incline. Use brake.

Make sure gear selector is in the desired direction of travel before depressing the accelerator. Do not change gear selector position while vehicle is moving.

Drive slowly in turns and up and down grades. Do not make turns on steep hills or inclines.

Do not operate while under the influence of alcohol or drugs.

To avoid the risk of injury or vehicle damage, operate at maximum speed only on smooth flat surfaces.

Allow additional stopping distance when traveling at higher speeds.

Do not drive this vehicle in hazardous areas unless this vehicle is approved and labeled for such operation.

Keep a safe distance when following other vehicles and from the edge of ramps and platforms.

Immediately report any accident or vehicle problem to your supervisor.

2.4 CHILD SAFETY

⚠ WARNING

Never leave a child or animal in a vehicle exposed to the sun with the windows closed.

Never leave the keys with a child in the vehicle.

Child seats are not recommended for this vehicle.

It is imperative to follow your local laws where you are driving, particularly in respect to driving with children of specific ages in the front seats of the vehicle.

2.5 CONCERNS

It is recommended that the operator and owner or renter of this vehicle comply with the OSHA requirements as stated in the Code of Federal Regulations, Section 29, 1910.178, Powered Industrial Truck Training Standard and the ANSI requirements as stated in Personnel and Burden Carriers ANSI B56.8.

At a minimum, every operator should, in addition to the above requirements found in the standards noted above:

- Demonstrate a working knowledge of each control.
- Understand all safety rules and guidelines as presented in this manual.
- Know how to properly load and unload cargo.
- Know how to properly park the vehicle.
- Recognize an improperly maintained vehicle.
- Demonstrate ability to handle the vehicle in all conditions.

Every owner or renter of this vehicle must, at a minimum:

- Define where the vehicles should be driven and utilized and should and who should not drive the vehicles.
- Ensure all proper warnings as to driving hazards are properly displayed and visible.
- Install safety signage concerning hills, speed bumps, ramps, turns, blind crossings, intersections, etc.
- Enforce safe driving and operating rules.
- Provide driver training for first time operators and review safe operating recommendations regularly.
- Maintain vehicles in a safe operating condition and maintain a schedule for daily, weekly, monthly, quarterly, semiannually and annual vehicle inspections.
- Determine who, when, and how pre-operation inspections be conducted.
- Notify operators what to do should an unsafe condition or operating problem be discovered.

3.0 OPERATIONS AND CONTROLS

3.1 IMPORTANT FIRST STEP

Upon initial delivery, it is very important that the battery pack is properly charged. This is required if the vehicle is to be stored for later use or is to be used immediately.

- Charging is complete when the Delta-Q green 100% charge LED lights. There is a remote LED located next to the charger receptacle. See Section 3.16.
- Vehicles with a single point watering system will require completion of 4 to 5 charge cycles before watering.

NOTICE: If the vehicle is not going to be used the Delta-Q Charger can remain connected to an AC source. It has the capability to test and recharge the battery pack during storage.

3.2 INSPECTING THE VEHICLE

After battery charging, perform a pre-delivery inspection of the vehicle. Also, before using the vehicle, there are checks that must be performed to ensure that it is in safe proper working order.

NOTICE: Vehicle should be inspected immediately after delivery. Use the following guidelines to make sure there are no obvious problems.

Examine the contents of all packages and accessories that may have come in separate packages with this vehicle. Make sure everything listed on the packing slip is there. Items should not be broken or damaged.

Examine any visible wiring for obvious signs of damage. Check that all connections are secure. Inspect the tires for obvious wear or damage. Check for proper tire inflation. Refer to recommendation in Section 1.2. Make sure that all wheel lugs are secure.

Check the body, seats, trim and other external parts for obvious damage. Look for body damage, jagged edges etc. that may cause personal injury.

Operate each of the following controls before turning on the power keyswitch.

- Accelerator Pedal for smooth operation.
- Braking Pedal, assure presence of a firm pedal with minimal travel.
- Steering, check for responsiveness and little play.
- Key can only be removed when keyswitch in "OFF" position.

NOTICE: Each control should operate smoothly and easily without sticking or requiring excessive effort.

Check that the directional selector operates properly, that the horn works and that the warning buzzer sounds in reverse.

If vehicle has just been delivered, report any physical damage or missing items to the shipping company and your local Columbia Dealer.

Report any battery or service issue problems to the individual(s) responsible for correction and/or repair or contact your local Columbia Dealer for service.

▲ DANGER

If any problems are found, do not operate vehicle until repairs are made. Failure to make necessary repairs could result in fire, severe personal injury, property damage or death. Consult your local Columbia Dealer for professional service.

3.3 SEATS AND SEAT BELTS

NOTICE: Adjust seat before driving. After adjustment, make sure seat is secure.

Adjusting Seat

Adjust driver's seat to allow easy operation of pedals, steering wheel and driver controls on dashboard.

Figure 3.3.1 is the driver's seat. To adjust seat position, move the handle (A) sideways and select seat position. To access batteries, adjust the seat fully forward, then lift release lever (B).

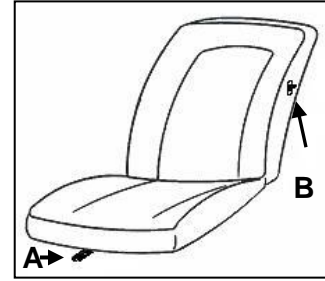

Figure 3.3.1

Seat Belts

Seat belts are self-adjusting. When attaching the seat belt, ensure that you are leaning back against the seat. The chest strap should be as close as possible, without restricting the neck. The abdominal strap should be placed flat against the thighs and abdomen.

See Figure 3.3.2. To fasten the seat belt, pull out the belt slowly and without pause, push buckle into lock (C) until you hear a light click. If the belt binds when pulling it out, release the belt and pull out again.

To unfasten the seat belt, push on the red button (D) and release the buckle from the lock.

When the belt is not in use, the belt buckle must be positioned near the wall mounting clip (E) with the adjustable clip (F).

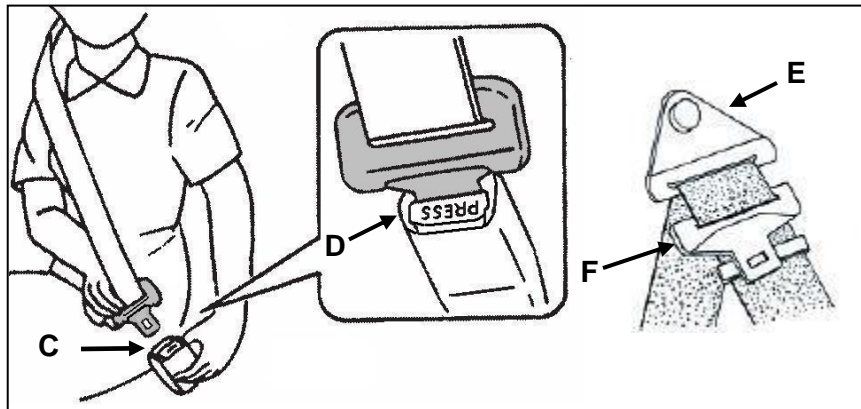

Figure 3.3.2

WARNING

Seat belts must be worn at all times when the vehicle is in motion.

Follow all local safety seat belt laws.

Important Seat Belt Information

- The seat belt is designed to hold one person. Never place a child on your knees and attach seat belt.
- Never use a device that interferes with the seat belt as there is a greater risk of injury in an accident if the seat belt is too loose.
- Following a serious accident, the seat belts in use at the time must be replaced. If any seat belt is faulty or damaged, it must be replaced immediately.
- If it is necessary to clean the seat belts, use only soap and water. The use of any other cleaning agents is prohibited.
- Improperly adjusted seat belts may cause injury in an accident.
- Pregnant women must wear a seat belt. Adjust the abdominal strap to avoid putting too much pressure on the abdomen.
- Do not attach abdominal strap under the arm or behind the back.
- When wearing seat belt, make sure strap is not twisted.
- The seat belts were designed for use by occupants of adult height.
- Do not modify or alter the seat belt, its attachment to the vehicle or the seats. Only use the manufacturer original equipment seat belts.
- Babies and infants should never be transported on the knees of a vehicle occupant.
- It is particularly dangerous to strap in a child while he/she is seated on your knees. Never use one seat belt for more than one person at a time.
- Child seats are not recommended for this vehicle.
- It is imperative to follow local laws where driving, particularly in respect to driving with children of specific ages in the front seats of the vehicle.

3.4 FRONT DOORS

Figure 3.4 shows the driver side door. Identified as A the inside door lock, B the inside door opener, C the window handle and D the outside door opener.

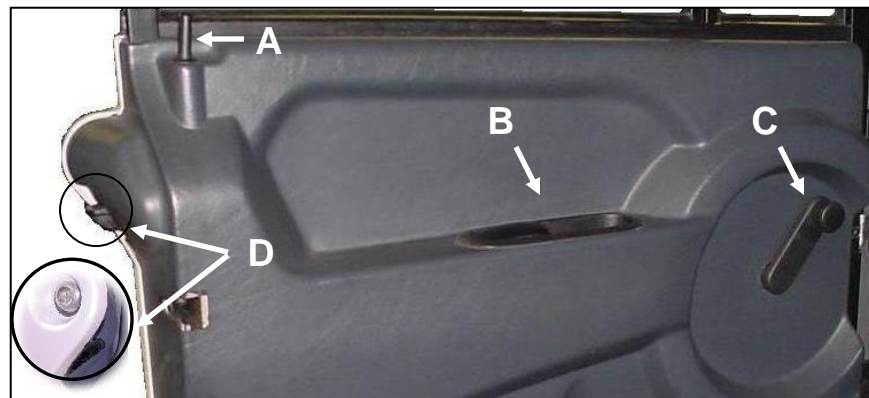

Figure 3.4

3.5 HEATER

See- Figure 3.5. The heating On/Off switch (A) will operate only if the fan switch (B) is in one of the three "ON" positions. It is advisable to use the electric heater (750W) intermittently. At continuous use, it will consume approximately 15% of the battery charge per hour.

The fan switch - has 4 positions. Off, Low, Medium, and High speed.

NOTICE: With this system, the actual heat output is the same regardless of the vent switch position. Selecting the higher speed positions will not increase the heater output and may create a cooling sensation.

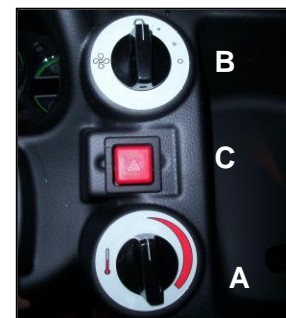
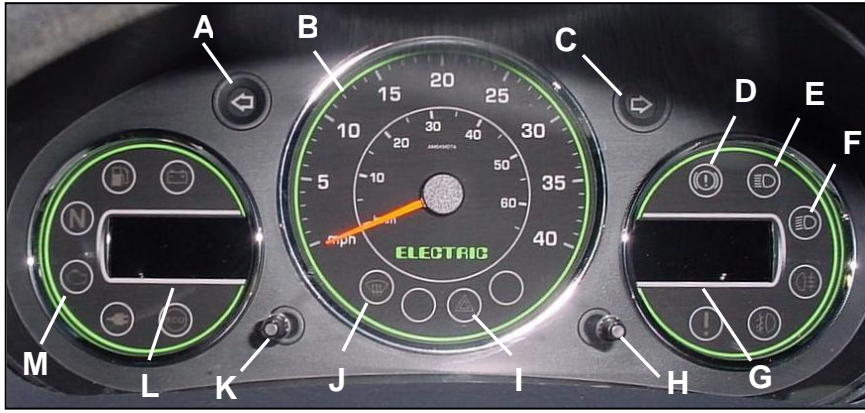

Figure 3.5

3.6 HAZARD WARNING FLASHER

See Figure 3.5. Push the button (C) to activate all four warning flashers. Push it again to deactivate.

3.7 INSTRUMENT PANEL – Figure 3.7



- A Left Turn Signal
- B Speedometer
- C Right Turn Signal
- D Handbrake Light
- E High Beam Indicator
- F Low beam Indicator
- G Hourmeter/Odometer
- H Right Screen Reset
- I Warning Light Indicator
- J Windshield Defrost Indicator
- K Left Screen Reset
- L Trip Meter
- M Service Engine

Figure 3.7

NOTICE: During daylight hours, the lighting system remains off and cannot be adjusted.

At night when the lighting system is functioning, adjust the brightness by repeatedly pressing on the Right-Screen Reset (Figure 3.7H). Brightness will increase with each press of the button. When maximum intensity is reached, it will revert back to the minimum intensity.

3.8 WINDSHIELD WIPER

See Figure 3.8. Wipers have OFF and three positions:

- 0 – OFF
- 1 - Intermittent
- 2 - Slow
- 3 – Fast

Pulling lever towards you activates the washer fluid (if equipped).

NOTICE: Do not operate wipers with the hood in a raised position.

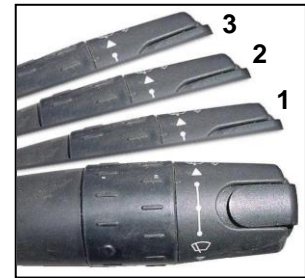

Figure 3.8

3.9 LIGHTS, HORN & TURN SIGNALS

See Figure 3.9. To turn lights on and off, rotate the control.

To change from low beam to high beam pull lever towards you.

Press the button on the end of the control to activate the horn.

Move the control down for left turn signal and up for right turn signal. Control will return to neutral position automatically when the turn is complete.



Figure 3.9

3.10 INTERIOR LIGHT (Optional)

See Figure 3.10. The interior light works only with the ignition key in the ON position. The light has 3 positions. Figure 3.8 shows the light in the OFF (middle) position. Pushing the top of the light is the permanently ON position. Pushing the bottom of the light is the position where the light is ON only when the left-side door is open



Figure 3.10

3.11 12V POWER OUTLET

See Figure 3.11. If equipped, a 12V power outlet is located above the glove box.

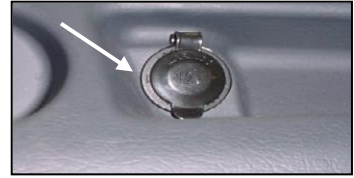

Figure 3.11

3.12 MULTI-FUNCTIONAL DISPLAY INDICATOR (MDI)

See Figure 3.12. Located to the left of the steering wheel, this meter will display the battery state of charge, an hour meter and the controller status. With fully charged batteries, the uppermost green LED is lit. A lit lower red LED indicates discharged batteries. The hour meter is an alpha-numeric liquid crystal display in the center of the MDI showing the hours worked.

If there is a controller error the hours worked will be replaced with a flashing error code. It is important to note the error code. It will aid a technician in corrective actions.



Figure 3.12

3.13 KEYSWITCH

See Figure 3.13.

ANTI-THEFT STEERING LOCK POSITION (A): To release the steering, lightly turn the wheel while gently turning the key.

ACCESSORIES POSITION (B)

RUNNING POSITION (C)

Do not leave the keyswitch in this position when the ignition is turned off or battery may discharge.

STARTER POSITION (D)

Not used on electric vehicles.

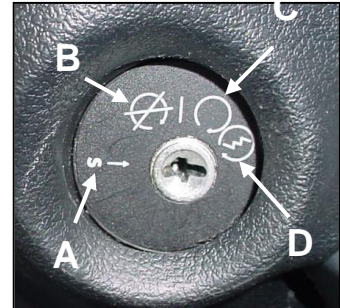

Figure 3.13

3.14 DIRECTIONAL KNOB

See Figure 3.14. With the keyswitch in the RUNNING position, move the directional knob to the desired direction of travel.

Move the lever to FL or FH to travel forward. The same speed occurs at either setting.

Move the lever to R to travel in reverse.

NOTICE: If the directional knob was in either forward or reverse when keyswitch was put in the Running position, move it to neutral (N), then back to the desired direction of travel.



Figure 3.14

3.15 HANDBRAKE

See Figure 3.15. To apply the handbrake, pull the handle up without pressing the button on the end of then handbrake.

To disengage the handbrake, gently pull up on the handle, push the button on the end of the handbrake and fully lower the handle.



Figure 3.15

3.16 CHARGER RECEPTACLE & REMOTE LED

See Figure 3.16. They are located outside the left hand door. The AC cord is plugged in here for battery charging. The charger is inter-locked with the traction control system which powers down the vehicle during charging. Near the receptacle is a remote multicolored LED which will indicate the Delta Q charge status. See Section 4.5.1 for information on the remote LED.

Always apply the parking brake when charging.



Figure 3.16

4.0 DRIVING THE VEHICLE

4.1 PRE-OPERATION CHECKLIST

⚠ CAUTION

Should any item malfunction or need adjustment. Do not operate vehicle until the problem has been corrected.

Complete the following PRE-OPERATION CHECKLIST

- Check position of rear view mirror.
- Check and adjust seat.
- Check battery capacity. Make sure vehicle is adequately charged to provide power during duration of operation.
- Check tires for proper inflation.
- Check lights, horn and reverse buzzer for proper operation.
- Check that brake pedal has firm pedal pressure with minimal travel.
- Check parking brake for proper engagement and release.
- Check that all warning and operation labels are in place.
- Check for smooth accelerator pedal operation.
- Make sure AC charger cord is disconnected.
- Put on and adjust seat belt.
- Check that payload limits and total authorized weight (includes weight of driver and passenger) have not been exceeded.

4.2 STARTING AND STOPPING

- Release the handbrake.
- Put the key in the RUNNING position and wait for the contact “click” and the sound of the ventilator motor fan running.
- Select the direction of travel with the directional knob.
- Press down on the accelerator.

⚠ CAUTION

To avoid using both pedals at the same time drive using only one foot. Engaging both the brake and accelerator at the same time will prematurely damage the vehicle systems and will lead to a reduction in range.

- To stop, press the brake and come to a complete stop. Engage the handbrake.

⚠ WARNING

When going downhill, the regeneration of the current through the braking system will cause the vehicle to slow down. This does not take the place of using the brake to slow the vehicle.

- Place the keyswitch in the **S** (Anti-Theft Steering Lock) position.

4.3 BATTERIES

Correct use of the batteries is as follows:

- Determine if a charge is required during the day.
- When storing, leave the vehicle plugged in to the main power supply. The charger will restart periodically to maintain the charge on the batteries.
- Drive economically in order to limit charge demand on the batteries.
- In winter or in low temperatures, always store the vehicle inside in order to maintain the range.

4.4 RECOMMENDED BREAK-IN PERIOD

To ensure vehicle remains reliable and economical, drive the vehicle as follows for the first 500 miles:

- Do not drive at high speeds.
- Avoid rapid starts, accelerating and braking excessively. Follow speed limits.

4.5 TILTBED/REFUSE LOADING

- The vehicle must be stationary and on level ground when being loaded.
- Do not load the vehicle using large machines (front end loaders, etc.). The load floor is made of aluminum and cannot withstand the force of objects being unloaded by large machines.
- The load must be in compliance with the payload as well as the weight distribution authorized per axle.
- The weight of the payload must be centered on the load floor and not exceed the height of the side panels (if equipped).

WARNING

When driving the vehicle, the load bed must be in the lowered position to avoid tipping over.

- When transporting leaves, grass, cuttings, branches or other loose material, a net (optional equipment) should be used to retain the items.
- Make sure the load does not exceed the length of the vehicle load area.

4.6 TILTBED/REFUSE RAISING & LOWERING

NOTICE: .Never place objects (tools, etc.) under the load bed outside of the storage compartment when bed is lowered. Damage to electrical, mechanical or hydraulic components could occur.

See Figure 4.6.

- To raise the load bed (for unloading); press the up button (A).
 - To lower the load bed, press the down button (B).
-
- The Refuse Tipper is equipped with a side door to facilitate easier loading.

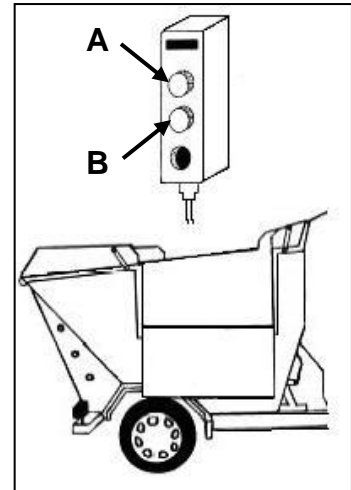

Figure 4.6

5.0 ELECTRICAL

5.1 IMPORTANT INFORMATION

The type of battery used in a Columbia vehicle has a service requirement which is quite different from that of an automotive battery.

The electric vehicle battery supplies all of the power to drive the vehicle. During operation the power stored in the batteries is expended. While the amperage drain rate can vary greatly depending on the type of service, the duration of use and the number of "starts" and "stops" made during a day, the batteries nevertheless progress through each duty cycle from "fully charged" to an almost depleted state.

This type of service is known as "deep cycle" service and electric vehicle batteries are specifically designed to handle this type of service.

Proper performance of your Columbia vehicle can only be obtained from specified deep cycle, electric vehicle batteries.

PLEASE REVIEW IMPORTANT DANGER, AND WARNING STATEMENTS WHEN WORKING AROUND BATTERIES AND CHARGING SYSTEMS!

⚠ DANGER

Always remove key and disconnect battery pack before servicing or repairing the vehicle.

Always wear full-face shield when working on or near batteries.

All batteries used in electric vehicles can explode! Batteries produce explosive hydrogen gas at all times, especially, during charging or discharging.

Ventilate area when charging batteries.

Do not attempt to charge a battery if it is frozen, or if the case is bulged excessively. Frozen batteries can explode! Properly dispose of the battery.

Do not smoke around batteries. Keep sparks and flames away from batteries and the charging area. Use care to prevent an accidental arc which could cause an explosion. Use only approved insulated tools, remove jewelry such as rings, watches, chains etc. and place an insulating material (wood, plastic, rubber etc.) over all battery connections.

Never add acid to a battery.

⚠ DANGER

Battery acid is poisonous and can cause severe burns. Avoid contact with skin, eyes, or clothing.

ANTIDOTES:

EXTERNAL: Flush with water. Call a physician immediately.

INTERNAL: Drink large quantities of milk or water. Follow with milk of magnesia or vegetable oil. Call a physician immediately.

EYES: Flush with water for fifteen minutes. Call physician immediately.

⚠ WARNING

To reduce the risk of electrical shock or injury:

Do not use an ungrounded two to three-prong adapter to connect the charger to a two-prong outlet or extension cord.

The battery charger must be properly grounded. Use a three prong No. 12 AWG heavy duty power cord with a ground conductor in good condition. Keep it as short as possible. No more than 50 feet.

Locate all cords so that they will not be stepped on, tripped on, or otherwise damaged. Immediately replace worn, cut, or damaged power cords or wires.

Do not connect the power cord near fuels, grain dust, solvents, thinners, or other flammables. The spark can ignite flammable materials and vapors.

NOTICE: Automotive batteries should never be used for “deep cycle” application, as their useful life will be very short.

Install surge arrestors on incoming AC power lines. Surge arrestors will help protect electrical/electronic components in the charge and vehicle from all but direct or ‘close proximity’ lightning strikes.

Damaged or corroded battery terminals should be replaced or cleaned as necessary. Failure to do so may cause overheating during operation.

NOTICE: Do not attempt to recharge batteries with a charger not designed for your vehicle.

Do not charge with caps off.

5.2 FUSE BOX - 48V CIRCUIT

- A fuse box protecting the 48V electrical circuits of the vehicle is located under the hood.
- To access the fuse box, raise the hood by pulling the hood latch located under the dash, above the accelerator pedal (Figure 5.2.1). Secure the hood in the upright position with the hood strut.

NOTICE: The windshield wiper switch must be in the OFF position and wipers in the “at rest” position, in order to open the hood.

- Remove the fuse box cover by removing the 3 thumbscrews securing the cover (Figure 5.2.2).



Figure 5.2.1



Figure 5.2.2

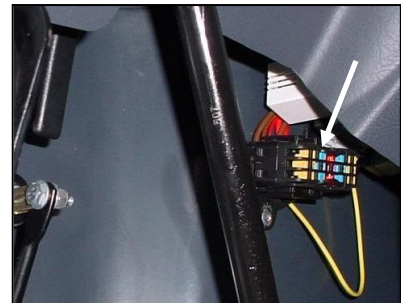

Figure 5.3

5.3 FUSE BOX - 12V CIRCUIT

- A fuse box protecting the 12V electrical circuits of the vehicle is located behind the dash near the steering column (Figure 5.3).
- This system runs the accessories (lights, horn, etc.)

NOTICE: If fuses continue to blow and require replacement, have your Columbia Dealer check the electrical circuit.

5.4 BATTERY MAINTENANCE

Use only distilled water. Vehicle batteries may use up to 16 quarts of water during their useful life and non-distilled water may contain harmful minerals which will have a cumulative adverse effect on battery performance and life.

Weekly an equalization charge is to be applied to the battery pack. This process balances the electrical charge in the battery pack and will extend battery life. The following procedure is used to complete this.

- Charge the battery pack allowing the Delta-Q Charger to go to green 100% charge. This status will also be shown on the remote LED.
- Once the green LED lights unplug the power cord.
- Wait approximately 30 seconds. Reconnect the power cord and allow the Delta-Q to complete a second charge cycle.
- If the vehicle is not to be used, leave power cord connected.

5.5 BATTERY CLEANING

Acid-soaked debris on the battery terminal connections causes current leakage, reduces battery efficiency, and battery life. Annually have your Columbia ParCar dealer clean the batteries.

5.6 CONDITIONS WHICH AFFECT CHARGING

Always schedule enough charging time so the Delta-Q Charger attains the 100% level. Charging time is affected by age and battery condition, state of discharge, electrolyte temperature, AC line voltage, and other variables. Correct charging methods extend battery life and vehicle range between charges.

New batteries need up to four hours more charging than “mature” batteries. Before the first use, completely charge new batteries. Charging time will vary based on conditions noted above but will probably be 12 hours.

If vehicle is used only occasionally, a refresher charge should be given prior to using.

Battery efficiency is affected by temperature. If the temperature of the outside air and/or batteries is below 60° F, battery capacity is reduced. Batteries will require more frequent and longer charge periods in early spring, fall and winter.

As batteries age, they finish charge at progressively higher charge rates and tend to use more distilled water. At this point in battery age, charger will automatically begin reducing charge time.

Batteries found defective must be replaced. All batteries in a vehicle should be matched according to age, capacity and brand.

5.7 DELTA-Q BATTERY CHARGING

All current production Columbia 24/36/48 volt electric vehicles are built with a new solid state on-board, fully automatic Delta-Q Battery Charger (Figure 5.7.1) as standard equipment. This section explains in more detail the Delta-Q Charger Operations. The Delta Q charge status can be found in two locations. On the Delta Q face and on a remote multicolored LED (Figure 5.7.2). This LED and descriptive label will be located near the Charger Receptacle.

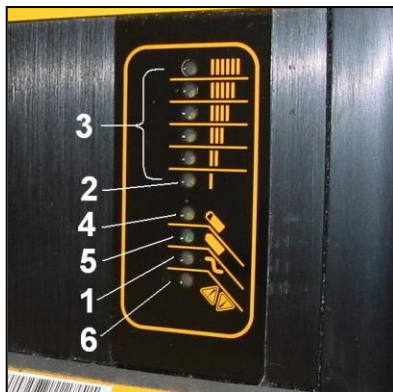

Figure 5.7.1



Figure 5.7.2

NOTICE: Do not cover the charger cabinet or cooling fins with clothing, blankets, or other material. Fins provide ventilation and prevent overheating.

Do not disassemble the charger. There are no serviceable components. Contact your Columbia dealer for service.

5.7.1 CHARGER OPERATION

Connect the supplied power cord to the vehicle Charger receptacle and to a properly grounded wall outlet. Charger start and charge time is automatic. The Yellow AC power LED (Fig. 5.7.1 No. 1) should remain illuminated while the Charger is plugged into an AC source. The remote LED will be flashing short green. If these LED's are not lit, before replacing Charger, recheck the AC connection and the AC source fuse or breaker. If this fails to correct the problem, contact your Columbia Dealer for assistance.

Charger will automatically turn on and conduct a short self-test and battery pack test. All LED's will flash in sequence and then a trickle current will be applied to batteries until a minimum voltage is reached. In Figure 5.7.1 No. 3 indicates the Bar Graph and No. 2 indicates the lowest LED. Three (3) amperes is displayed as the lowest LED on the Bar Graph.

If the batteries meet the minimum voltage requirements of the Charger, signifying they are serviceable (chargeable), the Charger enters the bulk charging (higher amperage-constant current) stage. The Bar Graph LED's indicate the electrical current being delivered to the batteries as the Charger moves through its automatic charge profile. The length of charge time at each level will vary due to battery size and battery charge depletion. The remote LED will be flashing short green.

NOTICE: If the batteries are excessively discharged, the Delta-Q Charger will not be able to charge the complete set of batteries. The Delta-Q RED FAULT LED (Fig. 5.7.1 No. 6) and the remote LED will be flashing red (see Section 5.7.2 Red Light Charger Error Codes). It will then be necessary to follow the Special Charging for Excessively Discharged Batteries, Section 5.8.

When the Yellow 80% LED (Fig 5.7.1 No. 4) is lit, the Charger has completed the bulk stage and the batteries are at approximately 80% state of charge. The 80% LED remains on as the last 20% of charge is returned to the batteries in the second phase (constant voltage phase). At this time the remote LED will flash long green.

NOTICE: You can terminate charging at this point if necessary. The vehicle can be used, but completing the charge cycle is highly recommended.

Repeated "Short Charging" leaving the charge short of 100% will shorten operating cycle distance and reduced battery life.

A low current "finish-charge" phase returns and maintains batteries to maximum capacity. The 100% Green LED will blink until "finish charge" phase is complete.

A 100% Green LED's continuously lit indicates the batteries are completely charged. The Charger may now be unplugged from the AC source. If the batteries will not be used for a length of time, check monthly for the charge level. It is also acceptable to leave the Charger plugged in. The Delta-Q has the capability to test and recharge if necessary.

A fault occurring while charging causes the RED FAULT LED and the remote LED to flash with a code relaying the error. Some errors may require repair by a qualified technician and others may be simply transient and will automatically recover when the fault condition is eliminated and the Delta-Q cycled by disconnecting the AC source for a minimum of 11 seconds.

NOTICE: A Yellow (Amber) blinking LED in the upper Bar Graph (Fig. 5.7.1 No. 3) and a flashing yellow remote LED usually indicates the thermostatic control has limited the Charger output due to ambient temperature conditions. It is still charging, but at a reduced rate.

5.7.2 RED LIGHT CHARGER ERROR CODES

1 FLASH = Battery Voltage High: Auto-recover. May be temporary condition, or wrong Charger installed, i.e. 36 volt Charger on 48 volt battery pack.

2 FLASH = Battery Voltage Low: Auto-recover. Confirm each individual batteries minimum voltage with a voltmeter. Two or more 6 volt batteries register less than 5.85 volts, or accumulative total pack voltage has been discharged to

less than 20% remaining. Vehicle operation will cease until batteries are recharged. See EXCESSIVELY DISCHARGED BATTERIES Section 5.8.

3 FLASH = Charge Timeout: The charging did not complete in allowed time, 12-14 hours. This may indicate a battery problem, or that the Charger output was reduced due to high ambient temperatures. Disconnect AC supply, confirm sufficient ventilation, allow cool down time, and restart Charger.

NOTICE: If the Delta-Q is exhibiting a 3 flash fault and it has been determined that the cause was not due to ventilation or high ambient temperature, the following procedure may restore the battery pack to normal operation.

- Battery posts and terminals must be clean and free of corrosion.
- Check that electrolyte level just covers plates.
- Plug in charger for at least a 16 hour charge.
- Check and fill electrolyte.
- Drive the vehicle for less than half the distance normally driven.
- Repeat the above steps until the Delta-Q goes green 100% charge on a 16 hour charge.

If repeated cycles (5-7) do not result in a 100% green charge, the batteries are beyond useful life and will need replacement.

4 FLASH = Check Battery: The batteries could not be trickle charged up to a minimum level to start Charger. This may be the result of badly discharged batteries, or one (or more) damaged cells. See EXCESSIVELY DISCHARGED BATTERIES Section 5.8.

5 FLASH = Over-Temperature: The Charger shutdown due to high internal temperature. May require reset (AC unplugged) and cool down to restart charging cycle. This fault may indicate inadequate cooling airflow or high ambient air temperatures. Check for debris or blockage at cooling fins. Move the vehicle to a cooler, well ventilated area, or adjust time of day when charging.

6 FLASH = Delta-Q Charger Fault: A fault was detected either in the batteries or in the Charger. The batteries must be tested to ensure there is no damage to one or more cells. If the batteries are found to be good, the Charger may need to be replaced by a qualified technician.

A STEADY RED FAULT LED confirms an internal electrical fault of the Delta-Q and requires Charger replacement and return.

5.7.3 CHECK / CHANGE CHARGING ALGORITHM

The Delta-Q Charger has been programmed for use with the Columbia ParCar supplied batteries and contains ten algorithms for use with different batteries. The Table 2 details these battery models.

NOTICE: For maximum battery life the correct algorithm must be used.

NOTICE: If your battery model is not listed in Table A, contact Delta-Q for further information.

TABLE A	
ALGORITHM #	BATTERY TYPE
126	Full River or Equivalent 85ah-145Ah AGM (DC115-12)
125	Full River or Equivalent 160ah-220ah AGM (DC180-6/DC224-6)
72	US Battery or Equivalent 250ah-335Ah Flooded Constant Power dv/dt (USB 305HC)
43	Discover or Equivalent 200ah-400ah AGM (EVL16A/EVGC6A/EV185A)
42	Discover or Equivalent 80ah-150ah AGM (EV31A)
11	US Battery or Equivalent 200ah-255ah flooded Constant Power dv/dt (USB2200/USB145)
5	Trojan or Equivalent 85ah-150ah Group 31 12v Flooded
1	Trojan or Equivalent 150ah-260ah 6v/8v/12v Flooded (T105)

Each time AC power is applied with the battery pack NOT connected, the charger enters an algorithm select/display mode for approximately 11 seconds. It will also be displayed on the remote LED.

During this time, the current algorithm # is indicated on the 80% LED light. A single digit algorithm # is indicated by the number of blinks separated by a pause. A two digit algorithm # is indicated by the number of blinks for the first digit followed by a short pause, then the number of blinks for the second digit followed by a longer pause.

To check/change the charging algorithm:

- Disconnect the charger positive connector from battery pack. Apply AC power and after the LED test, the algorithm # will be displayed for 11 seconds.
- To change the algorithm, touch the positive connector during the 11 second display period to the battery pack's positive terminal for 3 seconds and then remove. The algorithm # will advance after 3 seconds. Repeat until the desired algorithm # is displayed. A 30 second timeout is extended for every increment. Incrementing beyond the last algorithm moves back to the first algorithm. After the desired algorithm # is displayed touch the charger connector to the battery positive until the output relay is heard to click (~ 10 seconds). The algorithm is now in permanent memory.
- Remove AC power from the charger and reconnect the charger positive connector to the battery pack. It is highly recommended to check a newly changed algorithm by repeating the above steps.

5.8 EXCESSIVELY DISCHARGED BATTERIES

NOTICE: Columbia Dealer will have the equipment and experience to perform the following battery inspections.

The Delta Q will not charge dead batteries. First establish that none of the batteries have an internal fault or bad cell. If a battery has remained too long in a discharged state (i.e. 2-4 volts each), it may be internally damaged and not capable of accepting a charge and must be replaced.

If the electrolyte Specific Gravity is low (less than 1.1098 SG) or individual battery voltage is less than 5.25 volts for three cells (10.5 volts for six cells), recharge each battery with an ordinary automotive style trickle charger at a rate of 3 to 6 amps.

It is not necessary to disconnect the battery cables, as the alligator style clips can be connected to each positive and negative battery post. Follow specific Charger instructions.

▲ DANGER

To prevent a spark from igniting the gas emitted from the batteries, always disconnect the Charger AC power cord first when moving the positive/negative alligator clips.

Be sure to charge all of the batteries in the set. Each battery may require two to three hours of charging to bring it back to serviceable condition. After all batteries have been individually charged, remove the automotive Charger and restart charging with the Delta-Q Charger (Section 5.5). If again the Delta-Q Charger has the RED FAULT LED (Fig. 5.5.1A No. 6) flashing there is a problem with one or more of the batteries.

5.9 SPECIFIC GRAVITY TEST

It is possible to determine a battery's ability to perform by measuring the specific gravity (sp. gr.) of each cell with a hydrometer. This is the best method to determine a defective battery.

The hydrometer readings indicate two things:

- State of Charge - The amount of electrical power stored in the battery.
- Condition - The ability of battery to store and deliver power.

NOTICE: Batteries should be fully charged before performing specific gravity tests to determine battery condition. Hydrometer tests of batteries not fully charged are misleading and inconclusive.

There are different type hydrometers. Carefully read and follow the instructions supplied with your hydrometer.

NOTICE: Specific gravity readings are at 80°F. Values need adjustment for electrolyte temperature. Reduce .004 for every 10°F below 80°F. Increase by that amount for every 10°F above.

5.10 TIPS FOR PROLONGING BATTERY LIFE

NOTICE: A common misconception is Deep Cycle Batteries develop a memory, lose capacity, or must be discharged until the BDI warning flashes and then recharged. Deep Cycle Wet Lead Acid Batteries are not like cell phone NiCad Batteries. Deep Cycle Batteries benefit from frequent charging and being maintained at as close as possible to a 100% state of charge. Plugging in the Delta Q Charger overnight or when the vehicle is not in use for 3-5 or more days is encouraged.

- To prolong battery life, recharge batteries as soon as they become 20% or more discharged (less than 1.238 sp. gr.).
- Make it a regular habit to plug in the charger when the vehicle is not in use. Batteries may be recharged if vehicle has been driven 15 minutes or more since the previous charge.
- Make sure your electrical outlet is operational.
- Never go below 20% state of charge (or 80% discharged) without recharging immediately. Allow 14 – 16 hours of charging.
- Batteries will provide a longer life if not deeply discharged. Batteries that are regularly deeply discharged will require more work by the charger and will have a shorter life.
- Make it a regular habit to check (and water) your batteries after charging. Always add water after charging. This will reduce the chance for overflow due to expanding water.
- Weekly equalize the battery pack.
- If the vehicle is not operated daily the Power keyswitch should be turned off. This will power down the traction control system and reduces power loss on the batteries.
- Batteries in storage may self discharge and should be recharged when the specific gravity falls below 1.238 sp. gr.

5.11 BATTERY REMOVAL & INSTALLATION

See your Columbia ParCar dealer for battery removal or installation.

5.12 SINGLE POINT WATERING SYSTEM

This vehicle is equipped with a single point watering system for maintaining a sufficient electrolyte level in the batteries.

NOTICE: Do not operate this system on brand new batteries. Complete 4 to 5 charge cycles before using the system.

A fill tube assembly is used for adding water to the battery pack. It consists of a fill tube, one end having a filter screen, the other having a female coupler and a rubber squeeze bulb.

NOTICE: The single point watering system is to be used only after fully charging the batteries and batteries are warm.

Check the battery pack water level weekly by:

- Inserting the fill tube filter end in a distilled water supply.
- Attaching the female coupler to the battery pack male coupler.
- Squeeze the rubber ball until firm which indicates that filling is complete. Immediately disconnect the couplers by depressing the push button on the female coupler. If the water supply is left connected after the filling process is finished it could lead to an overflow.

6.0 SERVICING YOUR VEHICLE

6.1 MAINTENANCE GUIDELINES

⚠ DANGER

Always remove key and disconnect battery pack before servicing or repairing the vehicle.

Always wear full-face shield when working on or near batteries.

All batteries used in electric vehicles can explode! Batteries produce explosive hydrogen gas at all times, especially, during charging or discharging. Ventilate area when charging batteries.

Do not attempt to charge a battery if it is frozen, or if the case is bulged excessively. Frozen batteries can explode!

Properly dispose of the battery.

To ensure that the vehicle is kept in a safe and correct operating condition, it must be inspected and maintained on a regular basis. Proper lubrication, electrical control adjustments, safety feature checks, etc. performed at recommended intervals will help prevent damage or failure of the vehicle while providing optimum performance.

Follow the guidelines below to assure proper maintenance.

- Before starting any repairs or maintenance, immobilize the vehicle by turning the power keyswitch off, removing the key and setting the park handbrake.
- Disconnect both of the main battery pack leads before working on or disconnecting any electrical component or wire.
- Block the chassis with jack stands before working under a raised vehicle.
- Do not use flammable fluids for cleaning parts.
- Work in a properly ventilated work area.
- Regularly inspect and maintain in safe working condition: the brakes, steering mechanisms, speed and directional control mechanisms, warning devices, guards and safety devices.
- Keep the vehicle in a clean condition to minimize fire hazards and facilitate detection of loose or defective parts.

6.2 TILTBED SAFETY

Load bed must be empty before performing any maintenance. Before performing any maintenance or repair under the Tipper body, perform the following:

- Raise the load bed to the maximum height. See Figure 6.2.
- Remove the safety pin (1) from the housing (2) and insert pin into hole (3).

⚠ DANGER

Remove key and disconnect battery pack to prevent accidental activation of the load bed.

- After maintenance or repair is complete, remove the pin (1) from hole (3) and install in hole (2).
- Reconnect battery pack and lower the load bed.

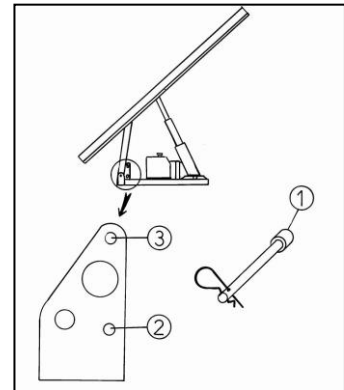

Figure 6.2

6.3 REFUSE SAFETY

⚠ DANGER

Remove key and disconnect battery pack to prevent accidental activation of the load bed.

Load bed must be empty before performing any maintenance. See Figure 6.3

Before performing any maintenance or repair under the Tipper body, perform the following:

- Raise the load bed to the maximum height.
- Unscrew the safety stand (1) and place it into the housing (2).
- After maintenance or repair is complete, remove the stand (1) from housing (2) and install in original position.
- Reconnect battery pack and lower the load bed.

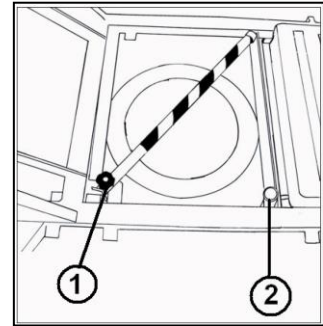

Figure 6.3

6.4 CLEANING

⚠ DANGER

The use of chemical product for cleaning is dangerous. Some are toxic while others can ignite when used close to an open flame or heat source. In poorly ventilated areas, inhalation of the fumes of particular substances can cause illness or poisoning. Read and follow directions carefully for all chemical products. The following products are prohibited for use on this vehicle.

- Gasoline
- Acetone
- Nail varnish remover
- Carbon tetrachlorine
- Varnish thinners
- Naphtha
- Teretentine essence
- Benzine
- Paint thinners

These products are dangerous and also risk damage to the vehicle

Cleaning the Cabin

- Vacuum the cabin to remove dust.
- Clean plastic panes with soap and water.
- Clean the upholstery and carpets with cleaning products designed for that use.

Cleaning the Body

Immediately clean the vehicle if it is exposed to elements that may corrode, discolor or stain the body such as:

- Sea water, chemical products used for de-icing roads in winter.
- Soot and dust, ash, chemical products (acids, tar, etc.).
- Do not use automatic car washes.
- Do not use steam or pressure washers.

Cleaning the Windows

Clean windows with soap and water, or a suitable glass cleaner. When using glass cleaner, avoid contact with the vehicle body.

Cleaning Tilt Mechanism

Check the tilt mechanism on a regular basis and clean all mechanical electrical and hydraulic components as necessary.

6.5 MAINTENANCE INDICATOR

- The MEGA Maintenance Indicator is represented by a small orange wrench and to its left, a mileage notation. See below.



- The indicator displays when the next maintenance service should be performed. One year or 3107 miles (5000 km) are the two parameters used for this calculation.
- After switching the ignition to position 2 for 5 seconds this indicator will show the mileage that is remaining before the next service is due. The wrench will also be lit. After 5 seconds the wrench will go out and the trip meter mileage will now be displayed.
- If the service distance has been reached or passed the wrench will light as well as the exceeded distance and a minus (-) sign. This will flash for 5 seconds. After 5 seconds the trip meter mileage is again displayed but the wrench will remain lit.
- Contact your authorized dealer for required servicing.
- After performing the required services, the Maintenance Indicator must be reset. Turn the keyswitch to the second position, after 5 seconds the wrench and a mileage are shown. At this point hold down both buttons on the dash. After 5 seconds the trip mileage will be displayed. After another 5 – 10 seconds, the word RESET will display. At this point turn the keyswitch off/on and the wrench and mileage display will indicate 3107 mi. (5000km). Depending upon the software version, it may be necessary to hold the reset buttons down prior to turning on the keyswitch.

NOTICE: To change from English to metric units, hold down the left reset button and turn the keyswitch on. The alternate measurement units will now be displayed.

6.6 MAINTENANCE SCHEDULE - OWNER/OPERATOR

Item	Operation	Weekly	Monthly	Semi-Annual
Tires	Lug nuts tight.		*	
	Check tire pressure, wear, damage. dented rims.		*	
Electrical	Check electrolyte level.	*		
	As required, clean battery terminals and wash cases.	*		
	Apply equalization charge to the battery pack.	*		
	Check the general condition of the electrical system (connections, frayed/broken cables).		*	
Brakes	Check pedal & park brake operation.		*	
Body and Frame	Inspect for loose hardware (bolts & nuts).	*		
	Clean body and seats, Wash as needed.	*		
	Wash engine compartment and undercarriage.	*		
Lube	Visual check for differential leak.		*	
	Oil movement points (body hinges, brake mechanisms and linkage, leaf spring bushings etc.).			*
Single Point Watering System	Add water per Section 4.10.	*		
	Check condition of tubing, couplers. Secure & leak free.		*	
	Clean filter screen.			*

6.7 MAINTENANCE SCHEDULE - QUALIFIED TECHNICIAN

It is recommended that the following be performed by a trained qualified technician or your Columbia Dealer

Item	Operation	Quarterly	Semi-Annual	Annual
Tires	Front wheel alignment and camber.		*	
Electrical	Clean and test batteries.			*
	Check vehicle faults.			
Brakes	Check brakes, clean, adjust, replace if needed.		*	
	Check brake fluid.	*		
	Check system for leaks.			
Lube	Check differential fluid level.			*
	Grease fittings- TiltBed only.		*	
Wheel	Check wheel axle nuts for tightness & torque.		*	
	When equipped, wheel bearings, repack, replace if needed.			*

6.8 SPARE TIRE (OPTIONAL)

When equipped with a spare tire, it is located under the rear floor (Figure 6.8.1). A jack is located in a box with the spare tire and a tire iron is clipped to the driver's seat base.

To change a wheel:

- Park the vehicle on firm, flat surface.
- Set the keyswitch to OFF, remove the key, engage the handbrake and wedge the vehicle wheels.
- Remove the spare tire, jack and tire iron.
- Remove the hub caps. Loosen the wheel nuts with the tire iron.
- Place the jack under the vehicle for the appropriate wheel to be changed; position 1 for rear wheels, position 2 for front wheels (Figure 6.8.2).
- Remove the lug nuts and wheel.
- Install spare wheel/tire and lug nuts. Tighten nuts in crisscross pattern as shown in Figure 6.8.3 and torque to 65 ft. lbs. (88.1 Nm).
- Install hub caps and lower vehicle to the ground.
- Store jack and tire iron in vehicle.
- Repair or replace the flat tire and replace the spare wheel as soon as possible.

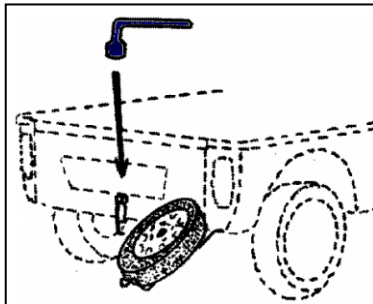

Figure 6.8.1

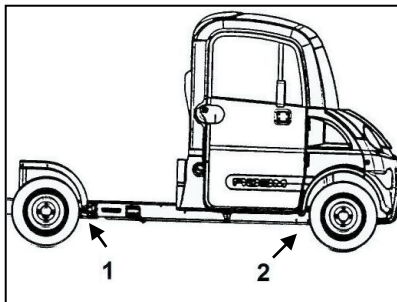

Figure 6.8.2

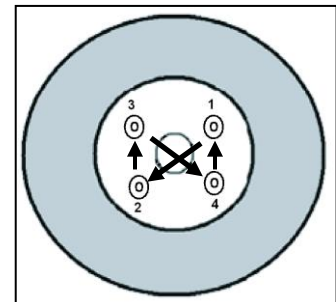

Figure 6.8.3

6.9 TIRE PRESSURE

Tires should be checked at regular intervals to ensure that they are not cracked or worn.

Fill tires to recommended 29 psi.

6.10 REPLACING BULBS

Headlight High Beam Bulb

Remove the waterproof cover (under the front quarter panel) and pull the bulb out to replace it.

Headlight Low Beam Bulb

Remove the waterproof cover (under the front quarter panel). Unclip the bulb holder and replace bulb.

Front Indicator Bulb

Access to the bulb is under the front wheel arch. Twist the bulb holder to remove and replace the bulb.

Rear Lights

Using a screwdriver, unscrew the two screws securing the transparent section of the rear light. Remove light to replace the bulb. Reinstall light with two screws.

Interior Light

Unclip the light from its support to replace the bulb.

6.11 CHECKING BRAKE FLUID LEVEL

Check the brake fluid in the master cylinder periodically (under normal conditions, every 3 months). Use DOT 3 Motor Vehicle Brake fluid. Maintain fluid level within 1/4" of master cylinder opening (Figure 6.11).

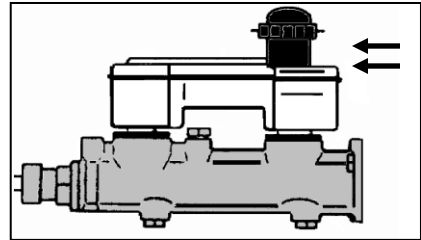

Figure 6.11

6.12 WINDSHIELD WASHER FLUID

Located under the hood, add fluid when necessary. Do not use alcohol based product.

6.13 TILT MECHANISM

Hydraulic Fluid

The hydraulic fluid should be changed every 4 years.

Fluid Type: HV46 Hydraulic

Quantity: 4.2 quarts

Greasing

Grease the two moving arms at regular intervals as well as the moving parts on the upper section of the ram.

Grease nipples are located at each part (Figure 6.13).

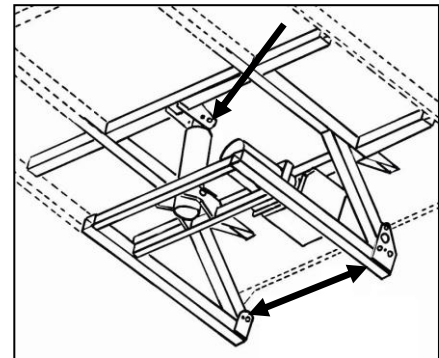

Figure 6.13

6.14 TRAILERING THE VEHICLE

NOTICE: Never transport a vehicle behind an auto or truck unless it is on an approved trailer.

When trailering your vehicle over long distances or on the highway observe the following:

- Use trailers specifically designed to carry your Columbia ParCar vehicle that meets all federal, state and local requirements.

- Secure vehicle to the trailer following trailer manufacturer's instruction.
- The key should be removed from the vehicle, the parking brake firmly locked, and the wheels blocked.
- On vehicles equipped with high or wide additions or accessories be certain they are secured properly to prevent loss or damage while trailering.

6.15 VEHICLE STORAGE (over 6 weeks)

Battery Preparation

Before storage make sure batteries are fully charged and the electrolyte is full in all cells per Section 5.4. Clean the batteries and connections per Section 5.5.

The Delta-Q charger has the capability to test and recharge batteries during storage. Leave the batteries connected and the Delta-Q charger plugged into a reliable AC source.

If the Delta-Q is not used:

- Batteries will "self-discharge" during storage and recharging will be necessary. Table B indicates the frequency for recharging.
- The specific gravity of the electrolyte should be checked every 6 to 8 weeks using a hydrometer. See Section 5.9 for further details.
- The batteries should be recharged to a specific gravity of approximately 1.260 sp. gr.
- After charging, disconnect the battery pack.

Table C indicates freezing points of batteries at different specific gravities.

TABLE B	
STORAGE TEMPERATURE	CHARGE AT
Below 4 ⁰ C (40 ⁰ F)	Every 6 months
4 ⁰ C - 16 ⁰ C (40 ⁰ - 60 ⁰ F)	Every 2 months
Above 16 ⁰ C (60 ⁰ F)	Once a month

TABLE C	
SPECIFIC GRAVITY	FREEZE POINT ⁰ F/ ⁰ C
1.260	-70/-57
1.230	-39/-38
1.200	-16/-26
1.117	-2/-19
1.110	+17/-8

⚠ DANGER

Batteries in a low state of charge will freeze at higher temperatures than fully charged batteries. Do not attempt to charge a battery that is frozen or if battery case is excessively bulged. Properly dispose of battery, because frozen batteries can explode.

NOTICE: Specific gravity readings are at 80⁰F. Values need adjustment for electrolyte temperature. Reduce .004 for every 10⁰F below 80⁰F. Increase by that amount for every 10⁰F above.

For vehicles with a single point watering system, quarterly during storage check water levels per Section 5.12.

Vehicle Preparation

- Store the vehicle in a cool place.
- Maintain tire pressure. See Section 1.2.
- Grease suspension and continue quarterly lubrication during storage period.
- Clean vehicle body, seats, battery compartment and vehicle underside.
- Do not engage park brake. Block wheels to prevent movement.

NOTICE: Make sure power keyswitch is in the OFF position.

Returning Vehicle to Service

- If necessary, connect the battery pack and fully recharge batteries.
- Check tire pressure and readjust if necessary.
- Complete pre-operation check per Section 4.1.

For vehicles with a single point watering system:

- After the batteries have been fully charged, connect the system to its water supply for 3-5 seconds then disconnect regardless of whether or not the batteries are completely full.
- Return the vehicle to its regular service.
- Place the vehicle back into its regular watering schedule (waiting at least 1 week until next watering).

6.16 VEHICLE TROUBLESHOOTING

PROBLEM	CHECK
Will not move	Power keyswitch ON, Direction selector in desired direction, Keyswitch for loose wires.
	Batteries for loose terminals, corrosion, electrolyte level or state of charge.
	Motor for loose wires.
Will not move with power keyswitch is ON and the direction selector is in the desired direction	Multi-Functional Display Indicator – See Section 3.12
Runs slow	Batteries for loose terminals, corrosion, electrolyte level or state of charge.
	Brakes dragging.
	Under inflated or flat tires.
	Wheels for binding, do not spin freely.
TiltBed does not rise, hydraulics does not make noise	Battery charge
	Remote control
	pump starter relay
TiltBed does not rise, hydraulics are working	Load weight
	Link between hole and pump
	Hydraulic hose for blocks or leaks
TiltBed partially rises	Fluid level
	TiltBed obstruction
If these test procedures do not resolve your vehicle problem, contact your Columbia Dealer for service.	



1115 Commercial Avenue • Reedsburg, WI 53959
Phone: (608) 524-8888 • Fax: (608) 524-8380
(800) 222-4653 • Web: www.parcar.com