



Owner and Operator Manual

EAGLE P4 Electric Vehicles



Preface

Welcome, and congratulations on your choice of vehicle from Columbia ParCar Corp.! Your vehicle has been manufactured in full compliance with all applicable American National Standards Institute (ANSI) standards. Your safe use and operation of your vehicle is important to us. Any alteration of your Columbia ParCar vehicle that results in the vehicle being in noncompliance with applicable ANSI standards is strictly prohibited. Columbia ParCar is not responsible or liable for any damage that results from any such alteration, and all warranties for any such altered vehicles are null and void.

Personal Transport Vehicles (PTV) are not designed for over-the-road use. They do not conform to Federal Motor Vehicle Safety Standards or EPA regulations, and are not equipped for operation on public streets, roads, or highways.

Low Speed Vehicles (LSV) commonly referred to as NEV or Neighborhood Electric Vehicles meet the requirements of the National Highway Traffic & Safety Administration (NHTSA) as stated in the Code of Federal Regulations, Title 49, Part 571, Standard 500, Low Speed Vehicles.

To the best knowledge of Columbia ParCar Corp., the material contained herein is accurate as of the date this publication was approved for printing. Columbia ParCar Corp. is not liable for errors in this manual or for incidental or consequential damages that result from the use of the material in this manual. Columbia ParCar Corp. reserves the right to change specifications, equipment or designs at any time without notice and without incurring obligation.

This manual contains proprietary information that is protected by copyright. All rights are reserved. No part of this manual may be photocopied, reproduced, or translated to another language without the written consent of Columbia ParCar Corp.

Columbia ParCar Corp. products are manufactured under one or more of the following U.S. Patents - 2986162, 2987934, 3116089, 3144631, 3144860, 3229792, 3434887, 3559773, 3673359, 3680403, 3683716, 3709317, 4648473, Des. 225626



1115 Commercial Avenue • Reedsburg, WI 53959
Phone: (608) 524-8888 • (800) 222-4653 • Web: www.parcar.com

TABLE OF CONTENTS

1.0 INTRODUCTION

- 1.1 SAFETY MESSAGES
- 1.2 VEHICLE IDENTIFICATION NUMBER
- 1.3 VIN MATRIX
- 1.4 VEHICLE SPECIFICATIONS

2.0 SAFETY

- 2.1 GETTING STARTED
- 2.2 SAFETY GUIDELINES
- 2.3 SAFETY VEHICLE STATEMENTS
- 2.4 BATTERY DISCONNECT METHODS

3.0 OPERATIONS AND CONTROLS

- 3.1 IMPORTANT FIRST STEP
- 3.2 INSPECTING THE VEHICLE
- 3.3 VEHICLE CONTROLS
 - 3.3.1 POWER KEYSWITCH
 - 3.3.2 DIRECTION SELECTOR
 - 3.3.3 LIGHT SWITCH
 - 3.3.4 AUXILIARY EQUIPMENT SWITCH
 - 3.3.5 BATTERY STATE OF CHARGE METER
 - 3.3.6 WARNING LABEL & OPERATING INSTRUCTIONS
 - 3.3.7 SYSTEM STATUS LIGHT
 - 3.3.8 BRAKE PEDAL/PARKING BRAKE
 - 3.3.9 ACCELERATOR PEDAL
 - 3.3.10 HOUR METER INDICATOR
 - 3.3.11 STEERING WHEEL
 - 3.3.12 CHARGER RECEPTACLE
 - 3.3.13 TURN SIGNAL/HAZARD WARNING SWITCH
 - 3.3.14 HORN BUTTON
 - 3.3.15 CAB HEATER
- 3.4 MAINTENANCE ACCESS
- 3.5 DRIVING THE VEHICLE
- 3.6 PRE-OPERATION CHECKLIST

4.0 ELECTRIC SYSTEM

- 4.1 IMPORTANT INFORMATION
- 4.2 BATTERY INSPECTION & MAINTENANCE
- 4.3 BATTERY CLEANING
- 4.4 CONDITIONS WHICH AFFECT CHARGING
- 4.5 BATTERY CHARGERS
- 4.6 DELTA Q CHARGING SYSTEM
 - 4.6.1 CHARGER OPERATING INSTRUCTIONS
 - 4.6.2 RED LIGHT CHARGER ERROR CODES
 - 4.6.3 CHECK / CHANGE CHARGING ALGORITHM
- 4.7 PRO CHARGING SYSTEM
 - 4.7.1 TROUBLE SHOOTING
 - 4.7.2 LIGHT EMITTING DIODES (LED) FAULT CODE INDICATIONS
- 4.8 EXCESSIVELY DISCHARGED BATTERIES
- 4.9 SPECIFIC GRAVITY TEST
- 4.10 TIPS FOR MAINTAINING YOUR BATTERIES
- 4.11 BATTERY REMOVAL & INSTALLATION
- 4.12 SINGLE POINT BATTERY WATERING SYSTEM

5.0 SERVICING YOUR VEHICLE

- 5.1 MAINTENANCE GUIDELINES
- 5.2 MECHANICAL BRAKE SYSTEM
- 5.3 HYDRAULIC BRAKE SYSTEM
- 5.4 BRAKE FLUID MAINTENANCE
- 5.5 TIRE CARE
- 5.6 WHEEL & TIRE REMOVAL/INSTALLATION
- 5.7 CLEANING
- 5.8 LUBRICATION
- 5.9 MAINTENANCE SCHEDULE - OWNER/OPERATOR
- 5.10 MAINTENANCE SCHEDULE - QUALIFIED TECHNICIAN
- 5.11 VEHICLE TROUBLESHOOTING
- 5.12 CONTROLLER TROUBLESHOOTING

6.0 TOWING & TRANSPORTING

- 6.1 TOWING YOUR VEHICLE
- 6.2 TRANSPORTING YOUR VEHICLE

7.0 VEHICLE STORAGE

- 7.1 BATTERY PREPARATION
- 7.2 VEHICLE PREPARATION
- 7.3 RETURNING VEHICLE TO SERVICE

NOTICE: In an effort to streamline product support, please ensure your vehicle is properly registered with Columbia ParCar. Registration allows for more effective product support including product updates and warranty processing. Please consult with your servicing dealer to verify or complete the registration process.

CHANGE HISTORY		
DATE	DESCRIPTION	BY
5/2011	Added above block	TS
7/11/12	Added Delta Q remote LED	TS
11/11/13	Corrected algorithm table	TS
5/11/15	Corrections and added PRO Charger, added LSV	TS

1.0 INTRODUCTION

This manual provides important safety information, operating instructions, model specifications and maintenance instructions for Eagle electric vehicles.

The information in this manual is limited to care and maintenance information only. Information covering repairs is provided in detailed service manuals available from Columbia Dealers. Such major repairs require the attention of a skilled technician and the use of special tools and equipment. Your Columbia Dealer has the facilities, experience and genuine Columbia vehicle parts and accessories to properly service Columbia vehicles.

1.1 SAFETY MESSAGES

Safety messages and other information in this manual are preceded by the words **DANGER**, **WARNING**, **CAUTION** or **NOTICE**. They are printed in bold face, and are very important. We recommend you take special notice of this information.

⚠ DANGER

Danger indicates a hazardous situation which, if not avoided, will result in death or serious injury.

⚠ WARNING

Warning indicates a hazardous situation which, if not avoided, could result in death or serious injury.

⚠ CAUTION

Caution indicates a hazardous situation which, if not avoided, could result in minor or moderate injury.

NOTICE: Notices are messages not related to personal injury. They will provide key information to prevent property damage and to assure procedures are more easily understood or implemented.

1.2 VEHICLE IDENTIFICATION NUMBER

Each vehicle contains a unique Vehicle Identification Number (VIN). The VIN describes facts and features of the vehicle and contains thirteen (13) digits. The VIN labels can be found in several locations.

Under the steering wheel cover as shown in Figure 1.2.1. Access to this location is by removing the three screws holding the cover in place.

The other location will be in the driver side glove box as shown in Figure 1.2.2.



Figure 1.2.1



Figure 1.2.2

To ensure prompt service when repairs or adjustments are required, your Columbia Dealer must have the VIN.

An example of a current VIN is P4LF4-3YF1234.

For your own personal reference, fill in the VIN in the space provided below:

1.3 VIN MATRIX

13 DIGIT VIN – USED AFTER FEBRUARY 2006

Digit 1 – 3 Model	P4L = Eagle - LE
	P4S = Eagle - SE
Digit 4 Power Systems	C = Sep. Ex, Plug: (<i>Smartdrive</i>)
	E = Sep Ex, Regen: (<i>ACEplus</i>)
	F = Sep Ex, Regen w/ encoder: (<i>ACEplus</i>)
Digit 5 Voltage/Batteries	3 = 36 Volt
	4 = 48 Volt (8 – 6 Volt)
	B = 48 Volt (4 – 12 Volt)
	G = 48 Volt Gel (8 – 6 Volt)
Digit 6 Standard or Special Product	- = Standard Product
	# = Special Product
Digit 7 Controller Amperage	3 = 300 Amp
	4 = 400 Amp
	5 = 500 Amp
Digit 8 Axle/Brake System	Z = H12: Rear Mechanical
	Y = H12: Rear Hydraulic
	X = H12: Front & Rear Hydraulic
Digit 9 Year Built	L = 2012, M = 2013, N = 2014, etc.
Digits 10 – 13 Build Sequence	0000 Through 9999

1.4 VEHICLE SPECIFICATIONS

	MODELS	
	LE-48	SE-48
Speed	19 mph	
Passenger Capacity	2	
Turning Curb to Curb	255 in.	
Ground Clearance	5 in.	
Wheelbase	64.5 in.	
Overall Length	96 in.	
Overall Width	45 in.	
Overall Height	51 in.	
Horsepower	15.3 HP @ 1750 rpm	17.3 HP @ 1750 rpm
Brakes	Auto adjusting, dual mechanical rear drum, parking brake automatically releases	

TIRES	RECOMMENDED PSI
215/60-8	22 – 25 psi
18.5 x 8.5 – 8 non-marking	22 – 25 psi
205/50-10	30 psi
480-12	32 psi
165/65R13	32 psi
215/50R13	32 psi
175/70R13	32 psi

DRIVE RATIO	
LE	12.44:1
SE	10.35:1

2.0 SAFETY

2.1 GETTING STARTED

For personal safety before operating the vehicle, it is the operator's responsibility to read, understand and follow the basic rules of operation and maintenance instructions in this manual. If you are responsible for the use of the vehicle, it is your responsibility to inform the person or persons using the vehicle about the following basic rules of operation for their personal safety.

It is Columbia ParCar Corporation's specific recommendation that the following warnings must be observed at all times. Not all are repeated throughout this manual, but the recommendations included must be observed whenever these subjects (vehicle operation hazards, battery hazards, etc.) are encountered. Section 4.0 ELECTRIC SYSTEM contains important safety and other system information.

Be a safe operator. Electric vehicles are only as safe as the person who is at the controls. If accidents are to be prevented, and they most certainly can be prevented, operators must accept their full measure of responsibility. While the designer, the manufacturer and the safety engineer can help minimize the possibility of an accident, their combined efforts can be erased by a single careless act.

2.2 SAFETY GUIDELINES

Observe the following guidelines for safe operation.

- Define **where** vehicles may be driven.
- Define **who** should be allowed to drive the vehicle.
- Instruct first-time drivers.
- **Maintain vehicles** in a safe driving condition.
- **Enforce** safe-driving **rules**.

2.3 SAFETY VEHICLE STATEMENTS

DANGER

This vehicle will not provide protection from lightning, flying objects, or other storm related hazards. If driving the vehicle in a storm, leave the vehicle and take shelter as per safety guidelines for your location.

Any modifications or changes to the vehicle that affect the stability, steering or that results in increased speed beyond factory specifications could result in vehicle damage, severe personal injury or death.

CAUTION

When replacement parts are required, use only genuine Columbia vehicle parts.

No modifications or additions, which affect the mechanical or electrical integrity and the safe operation of the unit, shall be made without the written approval of the manufacturer. If in doubt about any modification, contact your local Columbia Dealer or Columbia ParCar Corp. Customer Service.

⚠ WARNING

- **Follow** all procedures exactly and observe all safety messages stated in this manual.
- Working on vehicles without following proper procedures and using proper equipment may result in vehicle damage or personal injury.
- Do not attempt to service hot motor or components. Failure to observe this warning could result in severe burns.
- Always wear safety glasses or approved eye protection while servicing vehicle.
- Failure to maintain vehicle properly could result in decreased vehicle performance, reliability or cause severe personal injury.
- If any problems are found during scheduled maintenance or inspections, do not operate vehicle until repairs are made.

For personal safety and to maintain stability and control, operate this vehicle under these conditions only. Failure to comply with these warnings may result in bodily injury and property damage.

- All vehicles should be operated from the driver's side by authorized persons.
- Never exceed the capacity ratings of the vehicle. Exceeding these limits may endanger occupants.
- Personal injury may result if body parts (arms, head, and legs) are not kept inside vehicle while moving.
- Do not start moving until all occupants are seated. Remain seated and hold on while vehicle is in motion.
- Before leaving your seat, completely stop vehicle and lock parking brake. If vehicle is to be left unattended, turn keyswitch to "OFF" and remove key.
- Do not use accelerator to hold vehicle on an incline. Use brake.
- Make sure directional keyswitch is in position for the desired direction of travel before depressing the accelerator. Do not change the directional keyswitch while vehicle is moving.
- Drive slowly in turns and up and down grades. Do not make turns on steep hills or inclines.
- Do not operate while under the influence of alcohol or drugs.
- This vehicle is not Federal or State DOT approved and is not equipped to be operated on public roads or highways.
- To avoid the risk of injury or vehicle damage, operate at maximum speed only on smooth flat surfaces.
- Allow additional stopping distance when traveling at higher speeds.

These basic rules of operation, combined with courtesy and common sense, will help make driving your Columbia vehicle a safe and pleasant experience.

2.4 BATTERY DISCONNECT METHOD

The following illustrates the battery configuration. Disconnect both battery leads (Main Solenoid and Controller B-) before performing any vehicle service.

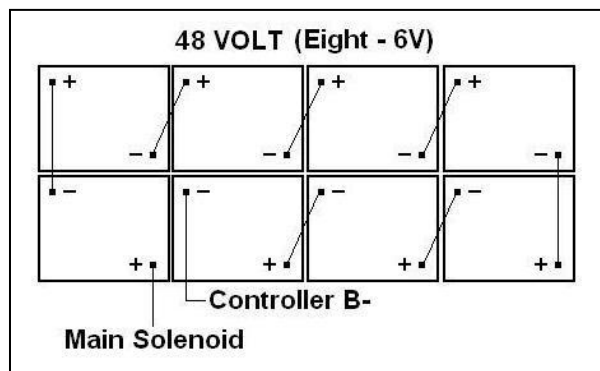

3.0 OPERATIONS AND CONTROLS

3.1 IMPORTANT FIRST STEP

Upon initial delivery, it is very important that the battery pack is properly charged. This is required if the vehicle is to be stored for later use or is to be used immediately.

- Check that the batteries are not damaged or leaking and that connections are tight.
- Remove the battery vent caps and inspect each cell for proper electrolyte level. The battery manifold assemblies on vehicles with a single point watering system will require a ¼ counterclockwise turn to be removed for this inspection.
- If the electrolyte level is below the plates add only enough water to cover the plates. See Section 4.2.

NOTICE: Do not overfill a cell. Electrolyte expands and can overflow during charging.

- For vehicles with a single point watering system, replace the manifold assemblies with a ¼ clockwise turn.
- With the electrolyte level correct, use the on board charger to charge the batteries as described in Section 4.
- Charging is complete when the green LED 100% charge is lit.
- Vehicles without a single point watering system, refill cells to below the bottom of the each cell vents. See Figure 4.2.1.
- Vehicles with a single point watering system will require completion of 4 to 5 charge cycles before watering.

NOTICE: If the vehicle is not going to be used the charger can remain connected to an AC source. It has the capability to test and recharge the battery pack during storage.

3.2 INSPECTING THE VEHICLE

After battery charging, perform a pre-delivery inspection of the vehicle. Also, before using the vehicle, there are checks that must be performed to ensure that it is in safe proper working order.

NOTICE: Vehicle should be inspected immediately after delivery. Use the following guidelines to make sure there are no obvious problems.

Examine the contents of all packages and accessories that may have come in separate packages with this vehicle. Make sure everything listed on the packing slip is there. Items should not be broken or damaged.

Examine any visible wiring for obvious signs of damage. Check that all connections are secure.

Inspect the tires for obvious wear or damage. Check for proper tire inflation. Refer to recommendations in Section 1.4. Make sure that all wheel lugs are secure.

Check the body, seats, trim and other external parts for obvious damage. Look for body damage, jagged edges etc. that may cause personal injury.

Operate each of the following controls before turning on the power keyswitch.

- Accelerator Pedal for smooth operation.
- Braking Pedal, assure presence of a firm pedal with minimal travel.
- Steering, check for responsiveness and little play.
- Key can only be removed when keyswitch in "OFF" position.

NOTICE: Each control should operate smoothly and easily without sticking or requiring excessive effort.

Check that the directional selector operates properly, that the horn works and that the warning buzzer sounds in reverse.

If vehicle has just been delivered, report any physical damage or missing items to the shipping company and your local Columbia Dealer.

Report any battery or service issue problems to the individual(s) responsible for correction and/or repair or contact your local Columbia Dealer for service.

⚠ DANGER

If any problems are found, do not operate vehicle until repairs are made. Failure to make necessary repairs could result in fire, severe personal injury, property damage or death. Consult your local Columbia Dealer for professional service.

3.3 VEHICLE CONTROLS

This section describes the operating controls of the vehicle. Figure 3.3.1 identifies many of these controls.

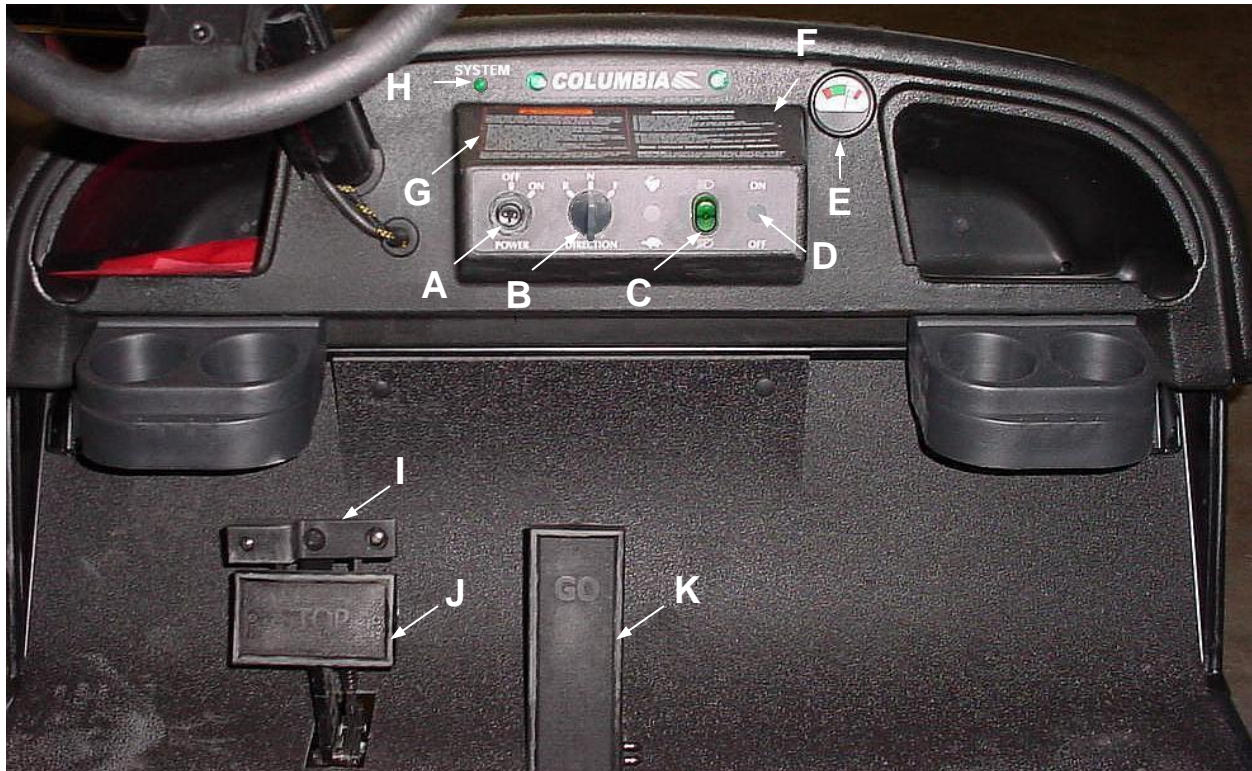

Figure 3.3.1

3.3.1 POWER KEYSWITCH – Figure 3.3.1 –Arrow A

With the power keyswitch in “OFF” position, the Traction System is powered down. This conserves battery energy by reducing the power draw when vehicle is not in use. Turning the power keyswitch to OFF is highly recommended whenever vehicle is not in use. Always take the key out of the keyswitch when leaving the vehicle.

3.3.2 DIRECTION SELECTOR – Figure 3.3.1 - Arrow B

When the direction selector is in the vertical position, the vehicle’s direction signal is turned OFF or in neutral.

Turn direction selector to the right from vertical position to move the vehicle in forward direction. Turn direction selector to the left from vertical position to move the vehicle in reverse direction. A warning buzzer sounds when in reverse.

NOTICE: Direction selector must be in the N or neutral position prior to turning on the ACEplus or Smartdrive power keyswitch, or a reset of the direction selector to neutral will be required before traction drive is enabled. See Section 5.12 CONTROLLER TROUBLESHOOTING.

3.3.3 LIGHT SWITCH – Figure 3.3.1 - Arrow C

Move switch up to activate headlights and taillights, down to turn off.

3.3.4 AUXILIARY EQUIPMENT SWITCH - Figure 3.3.1 Arrow D

A switch for auxiliary equipment will be located in this position.

3.3.5 BATTERY STATE OF CHARGE METER – Figure 3.3.1 Arrow E

This meter will display the battery state of charge. As shown, it is an analog gauge meter with an indicating needle and a colored background. It is a continuously reading meter. At rest with fully charged batteries the meter should read in the right white region.

When accelerating quickly, the needle will move to the left green region near the very far left red region. This is normal. If the needle continues past the green region into the very far left red region, it indicates that the batteries are 80% discharged or basically empty (only 20% charge remaining). Recharge as soon as possible to avoid a shut-down of the vehicle.

When decreasing speed, the needle will move to the right as electrical energy is being “regenerated” back into the batteries.

NOTICE: At 80% discharge, you must immediately charge batteries or vehicle operation will cease and permanent battery damage could occur.
--

3.3.6 WARNINGS & OPERATING INSTRUCTION – Figure 3.3.1 Arrow F & G

Read this information carefully before operating the vehicle. Promptly replace if removed or damaged. Contact Columbia ParCar for replacements if needed.

3.3.7 SYSTEM STATUS LIGHT – Figure 3.3.1 Arrow H

Some vehicle will be equipped with an additional green System Status LED light located on the dash.

With the power keyswitch in the “ON” position, the controller is powered up and this light should display a steady green light. If this green status light is not lit or is flashing refer to Section 5.12 CONTROLLER TROUBLESHOOTING.

3.3.8 BRAKE PEDAL/PARKING BRAKE

For vehicles with mechanical brakes Figure 3.3.1 shows the brake pedal (Arrow J) and the parking brake lock (Arrow I). The parking brake lock (Arrow I) is a bar located at the top of the brake pedal. To lock foot brake for parking, depress pedal and bar at the same time. Always apply parking brake when leaving the vehicle. It remains applied until automatically released by depressing the accelerator pedal. Parking brake can also be released by momentarily depressing the brake pedal, and then releasing it.

Figure 3.3.3 shows the brake pedal (Arrow L) and parking brake (Arrow N) for vehicles with hydraulic brakes. These vehicles will have a hand parking brake located either on the floor as shown in Figure 3.3.3 or if equipped with bucket seats, located between the seats. To lock the brake, pull the brake lever upward. To release, depress the button at the end of the handle and let the handle down to the original position. Always apply parking brake when leaving the vehicle.

Pressing the brake pedal activates brake lights and will slow or stop the vehicle.

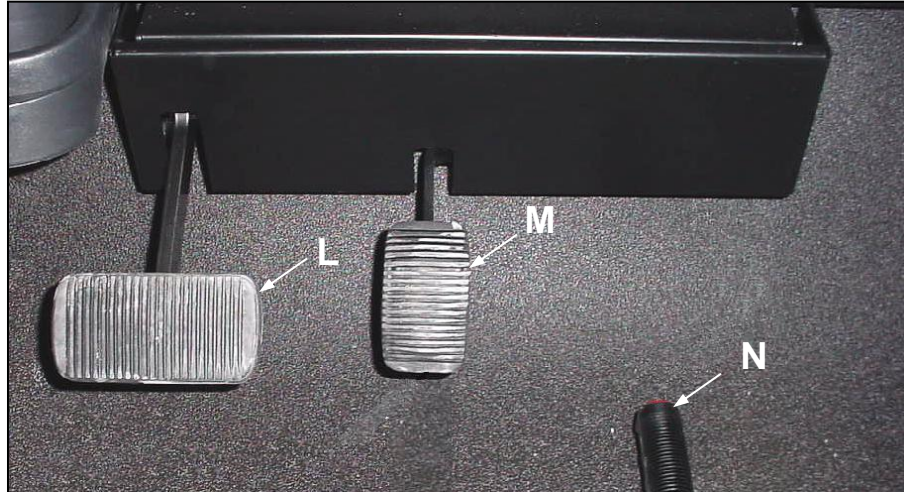

Figure 3.3.3

NOTICE: Do not operate the vehicle with the hand parking brake applied. Damage to the vehicle could result.

Never rest your foot on brake pedal while operating the vehicle. This wears brake pads, creates drag and causes excess battery discharge.

3.3.9 ACCELERATOR PEDAL

Figure 3.3.1 shows the accelerator pedal (Arrow K) for vehicles with mechanical brakes. Figure 3.3.3 shows the accelerator pedal (Arrow M) for vehicles with hydraulic brakes. They control the speed of the vehicle in the same manner as a conventional automobile. The pedal should be fully released when changing directions.

CAUTION

To avoid injury, speed in reverse should always be kept at a minimum.

3.3.10 HOUR METER INDICATOR – NOT SHOWN

If equipped, the hour meter indicates the total number of hours the vehicle has been operating. It would be located immediately below the Battery State of Charge meter.

3.3.11 STEERING WHEEL

The steering wheel controls the path of the vehicle exactly the same as a conventional automobile wheel.

3.3.12 CHARGER RECEPTACLE & REMOTE LED

The charger receptacle is located on the panel by the driver's left leg. The AC cord is plugged in here for battery charging. The charger is inter-locked with the traction control system which powers down the vehicle during charging. Near the receptacle is a remote multicolored LED which will indicate the battery charge status. See Section 4 for information on the remote LED.

Always apply the parking brake when charging.

NOTICE: Before removing the AC cord, be sure to check the LED Delta-Q charge status.

3.3.13 TURN SIGNAL/HAZARD WARNING SWITCH – Figure 3.3.4

The turn signal/hazard warning switch is located on the left side of the steering column. When lever (Arrow A) is moved upward the right turn signal turns on. When lever is moved downward the left turn signal turns on. To turn off a signal move indicator lever back to center position. To operate the hazard warning lights pull outward on hazard bar (Arrow B). Moving the signal indicator lever to either of the turn signal positions will turn off the hazard lights.

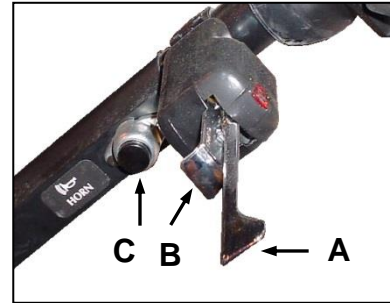

Figure 3.3.4

3.3.14 HORN BUTTON – Figure 3.3.4 Arrow C

The horn button is located on the left side of the steering wheel column, below the turn signals (if equipped). Press button to sound the horn.

3.3.15 CAB HEATER – Figure 3.3.5

The optional cab heater is equipped with a three position toggle switch. The CENTER position is off. To activate the heater and fan, move the switch to the UP position. To activate the fan only place the switch in the DOWN position.

NOTICE: If the toggle switch is in the Fan/Heat position and no heat is occurring a circuit reset is required. On a side panel there is a 3/8" hole. Inside is a reset tab. Using a non-conductive device push the tab to reset the circuit.



Figure 3.3.5

3.4 MAINTENANCE ACCESS

For vehicles with bench seats, to gain access for service and/or maintenance, lift midbody forward and rear body rearward. When closing, close the rear body first.

For vehicles with bucket seats, lifting the bucket seats will allow access only to the batteries.

3.5 DRIVING THE VEHICLE

- Complete the following PRE-OPERATION CHECKLIST.
- Fasten seat belts (if vehicle is so equipped).
- Insert key in power keyswitch, press brake pedal firmly, and turn key to "ON" position.
- Switch the direction selector to the direction of desired travel.
- Release the parking brake and brake pedal.
- Slowly press accelerator pedal to obtain desired vehicle speed.
- To slow or stop vehicle, remove foot from accelerator and press brake pedal.

3.6 PRE-OPERATION CHECKLIST



Should any item malfunction or need adjustment, do not operate vehicle until the problem has been corrected.

ITEM	PROCEDURE
Batteries	Fully charged or adequately charged to provide power for duration of operations.
	The AC cord is disconnected from the vehicle.
	Electrolyte level in each cell covers the top of cell plates. (See Section 4.12 if vehicle is equipped with a Single Point Battery Watering System.)
	Batteries are secure and free of corrosion.
	All terminals and connections are tight.
Tire Pressure	Inflated to recommendation per Section 1.4. Do not exceed maximum stated on tire sidewall.
Lights, Horn and Reverse Buzzer	Head, tail and brake lights illuminate.
	Press horn button to sound horn.
	Reverse buzzer sounds.
Brakes	Brake pedal has firm pedal pressure with minimal travel.
	Parking brake has proper engagement and release.
Steering	Responsiveness and the absence of excessive free play.
Cargo	Load is secure, balanced and not top heavy.
Obstacles	Path of intended travel is free from obstructions.
Seat Belts	If equipped, driver and passenger are secured by seatbelts before moving vehicle.
Labels	All warning and operation labels in place.
Accelerator	Check for smooth operation.

4.0 ELECTRIC SYSTEM

4.1 IMPORTANT INFORMATION

The type of battery used in a Columbia vehicle has a service requirement which is quite different from that of an automotive battery.

The electric vehicle battery supplies all of the power to drive the vehicle. During operation the power stored in the batteries is expended. While the amperage drain rate can vary greatly depending on the type of service, the duration of use and the number of "starts" and "stops" made during a day, the batteries nevertheless progress through each duty cycle from "fully charged" to an almost depleted state.

This type of service is known as "deep cycle" service and electric vehicle batteries are specifically designed to handle this type of service.

Proper performance of your Columbia vehicle can only be obtained from specified deep cycle, electric vehicle batteries.

PLEASE REVIEW IMPORTANT DANGER, AND WARNING STATEMENTS WHEN WORKING AROUND BATTERIES AND CHARGING SYSTEMS!

⚠ DANGER

Always remove key and disconnect battery pack before servicing or repairing the vehicle. See Section 2.4.

Always wear full-face shield when working on or near batteries.

All batteries used in electric vehicles can explode! Batteries produce explosive hydrogen gas at all times, especially, during charging or discharging. Ventilate area when charging batteries.

Do not attempt to charge a battery if it is frozen, or if the case is bulged excessively. Frozen batteries can explode! Properly dispose of the battery.

Do not smoke around batteries. Keep sparks and flames away from batteries and the charging area. Use care to prevent an accidental arc which could cause an explosion. Use only approved insulated tools, remove jewelry such as rings, watches, chains etc. and place an insulating material (wood, plastic, rubber etc.) over all battery connections.

Never add acid to a battery.

⚠ DANGER

Battery acid is poisonous and can cause severe burns. Avoid contact with skin, eyes, or clothing.

ANTIDOTES:

EXTERNAL: Flush with water. Call a physician immediately.

INTERNAL: Drink large quantities of milk or water. Follow with milk of magnesia or vegetable oil. Call a physician immediately.

EYES: Flush with water for fifteen minutes. Call physician immediately.

⚠ WARNING

To reduce the risk of electrical shock or injury:

Do not use an ungrounded two to three-prong adapter to connect the charger to a two-prong outlet or extension cord.

The battery charger must be properly grounded. Use a three prong No. 12 AWG heavy duty power cord n more than 50 feet long.

Locate all cords so that they will not be stepped on, tripped on, or otherwise damaged. Immediately replace worn, cut, or damaged power cords or wires.

Do not connect the power cord near fuels, grain dust, solvents, thinners, or other flammables. The spark can ignite flammable materials and vapors.

NOTICE: Automotive batteries should never be used for "deep cycle" application, as their useful life will be very short.

Install surge arrestors on incoming AC power lines. Surge arrestors will help protect electrical/electronic components in the charger and vehicle from all but direct or "close proximity" lightning strikes.

Damaged or corroded battery terminals should be replaced or cleaned as necessary. Failure to do so may cause overheating during operation.

Do not attempt to recharge batteries with a charger not designed for your vehicle.

Only trained technicians should service the Delta Q charger. Contact your Columbia Dealer for assistance.

4.2 BATTERY INSPECTION & MAINTENANCE

Check the electrolyte level on new batteries before they are put into service, and, at a minimum, once a week thereafter. Water use increases as batteries age. (See Section 4.11 if vehicle is equipped with a Single Point Battery Watering System.)

See Figure 4.2.1. Never allow the electrolyte level (A) to fall below the top of the plates (C). If the plates are exposed, add only enough to cover the plates before charging. After batteries are fully charged, fill cells to just below the bottom of the cell vents (B), approximately 1/8" to 1/4". Electrolyte level should not touch the bottom of the cell vents.

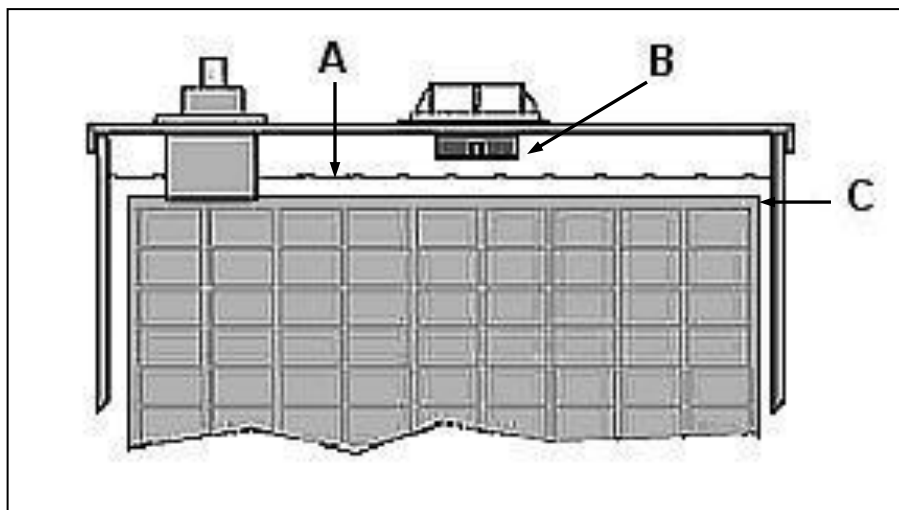

Figure 4.2.1

Do not overfill batteries. Electrolyte expands and can overflow during charging. Water added to replace the spillage dilutes the electrolyte and reduces its specific gravity.

Use only distilled water. Vehicle batteries may use up to 16 quarts of water during their useful life and non-distilled water may contain harmful minerals which will have a cumulative adverse effect on battery performance and life.

Be sure battery hold downs are properly tightened. A loose hold down may allow the battery to become damaged from vibration or jarring. A hold down that is too tight may buckle or crack the battery case.

Weekly inspect battery posts, clamps and cables for breakage, loose connections and corrosion. Replace any that are damaged. Check to see that battery cap vent holes are clear. Plugged vent holes will not permit gas to escape from the cell and could result in battery damage. Batteries and connections must be clean and dry. See Section 4.3.

Monthly an equalization charge is to be applied to the battery pack. This process balances the electrical charge in the battery pack and will extend battery life. The following procedure is used to complete this.

- Charge the battery pack allowing the charger to go to green 100% charge.
- Once the green LED lights unplug the power cord.
- Wait approximately 30 seconds. Reconnect the power cord and allow the charger to complete a second charge cycle.
- If the vehicle is not to be used, leave power cord connected. The charger can test and recharge as needed.

4.3 BATTERY CLEANING

Acid-soaked debris on the battery terminal connections will cause current leakage, reduces battery efficiency, and battery life.

Check that all vent caps are tightly in place. Hose wash battery terminal connections periodically with clean low-pressure water to keep them free of acid spillage, dirt, and other debris. Do not hose wash electronic controllers, switches, solenoids and other electrical control devices. Cover as necessary to prevent splashing.

Clean battery terminal connections with baking soda (sodium bicarbonate) and water solution. Mix 5 teaspoons baking soda per quart of water. Use a stiff bristle brush, rinse with clean water and dry with a clean cloth. Do not allow solution to enter cap vent holes.

NOTICE: Follow local ordinances and codes for proper disposal of battery cleaning waste.

4.4 CONDITIONS WHICH AFFECT CHARGING

Always schedule enough charging time so the charger attains the 100% level. Charging time is affected by age and battery condition, state of discharge, electrolyte temperature, AC line voltage, and other variables. Correct charging methods extend battery life and vehicle range between charges.

New batteries need up to four hours more charging than “mature” batteries. Before the first use, completely charge new batteries. Charging time will vary based on conditions noted above but will probably be 12 hours.

Limit new batteries use between charges for the first 25 – 50 cycles. New batteries have less capacity than seasoned batteries. New batteries should not be discharged more the 20 – 30% before recharging. This will prevent premature battery failure.

Battery efficiency is affected by temperature. If the temperature of the outside air and/or batteries is below 60° F, battery capacity is reduced. Batteries will require more frequent and longer charge periods in early spring, fall and winter.

As batteries age, they finish charge at progressively higher charge rates and tend to use more distilled water. At this point in battery age, charger will automatically begin reducing charge time.

Batteries found defective must be replaced. All batteries in a vehicle should be matched according to age, capacity and brand.

4.5 BATTERY CHARGERS

All current production Columbia 24/36/48 volt electric vehicles are built with new solid state on-board, fully automatic high-frequency, programmable battery charger as standard equipment. Two different charging systems are used. Vehicles can be equipped with a DELTA Q Charging System or a PRO Charging System.

4.6 DELTA-Q BATTERY CHARGING

The Delta Q charge status can be found in two locations. On the Delta Q face and on a remote multicolored LED (Figure 4-6B). This LED and descriptive label will be located near the Charger Receptacle.

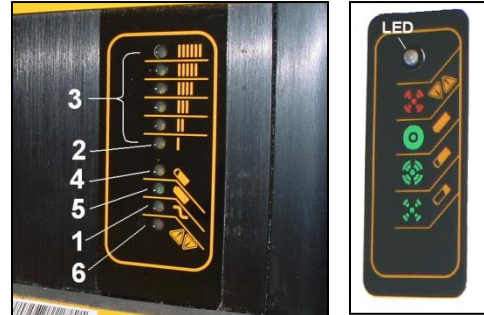

Figure 4.6A

Figure 4.6B

NOTICE: Do not cover the charger cabinet or cooling fins with clothing, blankets, or other material. Fins provide ventilation and prevent overheating.

Do not disassemble the charger. There are no serviceable components.

4.6.1 CHARGER OPERATING INSTRUCTIONS

Connect the supplied power cord to the vehicle charger receptacle and to a properly grounded wall outlet. Charger start and charge time is automatic. The Yellow AC power LED (Fig. 4.6A No. 1) should remain illuminated while the Charger is plugged into an AC source. The remote LED will be flashing short green. If these LED's are not lit, before replacing Charger, recheck the AC connection and the AC source fuse or breaker. If this fails to correct the problem, contact your Columbia Dealer for assistance.

Charger will automatically turn on and conduct a short self-test and battery pack test. All Delta Q LED's will flash in sequence and then a trickle current will be applied to batteries until a minimum voltage is reached. In Figure 4.6A No. 3 indicates the Bar Graph and No. 2 indicates the lowest LED. Three (3) amperes is displayed as the lowest LED on the Bar Graph.

If the batteries meet the minimum voltage requirements of the Charger, signifying they are serviceable (chargeable), the Charger enters the bulk charging (higher amperage-constant current) stage. The Delta Q Bar Graph LED's indicate the electrical current being delivered to the batteries as the Charger moves through its automatic charge profile. The length of charge time at each level will vary due to battery size and battery charge depletion. The remote LED will be flashing short green.

NOTICE: If the batteries are excessively discharged, the Delta-Q Charger will not be able to charge the complete set of batteries. The Delta-Q RED FAULT LED (Fig. 4.6A No. 6) and the remote LED will be flashing red. (See Section 4.6.2 Red Light Charger Error Codes). It will then be necessary to follow the Special Charging for Excessively Discharged Batteries, Section 4.6.

When the Yellow 80% LED (Fig 4.6A No. 4) is lit, the Charger has completed the bulk stage and the batteries are at approximately 80% state of charge. The 80% LED remains on as the last 20% of charge is returned to the batteries in the second phase (constant voltage phase). At this time the remote LED will flash long green.

NOTICE: You can terminate charging at this point if necessary. The vehicle can be used, but completing the charge cycle is highly recommended.

Charge completion is when the 100% Green LED is lit (Fig. 4.6A No. 5). The remote LED will be green.

Repeated "Short Charging" leaving the charge short of 100% will shorten operating cycle distance and reduced battery life.

A Green LED continuously lit indicates the batteries are completely charged. The Charger may now be unplugged from the AC source. If the batteries will not be used for a length of time, check monthly for the charge level. It is also acceptable to leave the Charger plugged in. The Delta-Q has the capability to test and recharge if necessary.

A fault occurring while charging causes the RED FAULT LED and the remote LED to flash with a code relaying the error. Some errors may require repair by a qualified technician and others may be simply transient and will automatically recover when the fault condition is eliminated and the Delta-Q cycled by disconnecting the AC source for a minimum of 11 seconds.

NOTICE: A Yellow (Amber) flashing LED in the upper Bar Graph (Fig. 4.6A No. 3) and a flashing yellow remote LED indicates the thermostatic control has limited the Charger output due to ambient temperature conditions. It is still charging, but at a reduced rate.

4.6.2 RED LIGHT CHARGER ERROR CODES

1 FLASH = Battery Voltage High: Auto-recover. May be temporary condition, or wrong Charger installed, i.e. 36 volt Charger on 48 volt battery pack.

2 FLASH = Battery Voltage Low: Auto-recover. Confirm each individual batteries minimum voltage with a voltmeter. Two or more 6 volt batteries register less than 5.85 volts, or accumulative total pack voltage has been discharged to less than 20% remaining. Vehicle operation will cease until batteries are recharged. See EXCESSIVELY DISCHARGED BATTERIES Section 4.6.

3 FLASH = Charge Timeout: The charging did not complete in allowed time, 12-14 hours. This may indicate a battery problem, or that the Charger output was reduced due to high ambient temperatures. Disconnect AC supply, confirm sufficient ventilation, allow cool down time, and restart Charger.

NOTICE: If the Delta-Q is exhibiting a 3 flash fault and it has been determined that the cause was not due to ventilation or high ambient temperature, the following procedure may restore the battery pack to normal operation.

- Battery posts and terminals must be clean and free of corrosion.
- Check that electrolyte level just covers plates.
- Plug in charger for at least a 16 hour charge.
- Check and fill electrolyte.
- Drive the vehicle for less than half the distance normally driven.
- Repeat the above steps until the Delta-Q goes green 100% charge on a 16 hour charge.

If repeated cycles (5-7) do not result in a 100% green charge, the batteries are beyond useful life and will need replacement.

4 FLASH = Check Battery: The batteries could not be trickle charged up to a minimum level to start Charger. This may be the result of badly discharged batteries, or one (or more) damaged cells. See EXCESSIVELY DISCHARGED BATTERIES Section 4.6.

5 FLASH = Over-Temperature: The Charger shutdown due to high internal temperature. May require reset (AC unplugged) and cool down to restart charging cycle. This fault may indicate inadequate cooling airflow or high ambient air temperatures. Check for debris or blockage at cooling fins. Move the vehicle to a cooler, well ventilated area, or adjust time of day when charging.

6 FLASH = Delta-Q Charger Fault: A fault was detected either in the batteries or in the Charger. The batteries must be tested to ensure there is no damage to one or more cells. If the batteries are found to be good, the Charger may need to be replaced by a qualified technician.

A STEADY RED FAULT LED confirms an internal electrical fault of the Delta-Q and requires Charger replacement and return.

4.6.3 CHECK / CHANGE CHARGING ALGORITHM

The Delta-Q Charger has been programmed for use with the Columbia ParCar supplied batteries and contains ten algorithms for use with different batteries. The Table A details these battery models.

TABLE A	
ALGORITHM #	BATTERY TYPE
126	Full River or Equivalent 85ah-145Ah AGM (DC115-12)
125	Full River or Equivalent 160ah-220ah AGM (DC180-6/DC224-6)
72	US Battery or Equivalent 250ah-335Ah Flooded Constant Power dv/dt (USB 305HC)
43	Discover or Equivalent 200ah-400ah AGM (EVL16A/EVGC6A/EV185A)
42	Discover or Equivalent 80ah-150ah AGM (EV31A)
11	US Battery or Equivalent 200ah-255ah flooded Constant Power dv/dt (USB2200/USB145)
5	Trojan or Equivalent 85ah-150ah Group 31 12v Flooded
1	Trojan or Equivalent 150ah-260ah 6v/8v/12v Flooded (T105)

NOTICE: For maximum battery life the correct algorithm must be used.

NOTICE: If your battery model is not listed in Table A, contact Delta-Q for further information.

Each time AC power is applied with the battery pack NOT connected, the charger enters an algorithm select/display mode for approximately 11 seconds. This is also displayed on the remote LED. During this time, the current algorithm # is indicated on the 80% LED light. A single digit algorithm # is indicated by the number of blinks separated by a pause. A two digit algorithm # is indicated by the number of blinks for the first digit followed by a short pause, then the number of blinks for the second digit followed by a longer pause.

To check/change the charging algorithm:

- Disconnect the charger positive connector from battery pack. Apply AC power and after the LED test, the algorithm # will be displayed for 11 seconds.
- To change the algorithm, touch the positive connector during the 11 second display period to the battery pack's positive terminal for 3 seconds and then remove. The algorithm # will advance after 3 seconds. Repeat until the desired algorithm # is displayed. A 30 second timeout is extended for every increment. Incrementing beyond the last algorithm moves back to the first algorithm. After the desired algorithm # is displayed touch the charger connector to the battery positive until the output relay is heard to click (~ 10 seconds). The algorithm is now in permanent memory.
- Remove AC power from the charger and reconnect the charger positive connector to the battery pack. It is highly recommended to check a newly changed algorithm by repeating the above steps.

4.7 PRO CHARGING SYSTEM

When your battery charging system is activated, the battery status indicator (Figure 4.7.1) provides charging information utilizing five red LED indicators and one green LED indicator.

Battery Type Indicators

Two amber LED indicators are provided in order to display what type of battery the charger has been programmed to charge.

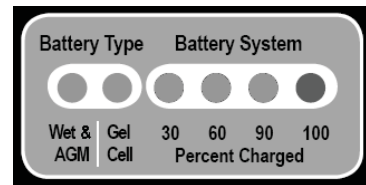

Figure 4.7.1

NOTICE: For information on reconfiguring the battery type, please contact ParCar technical support.

Battery System Percent Charged Indicators

Four LED indicators are provided in order to display the progress of the charge cycle in percentage of charge.

Indications are as follows:

1ST AMBER LEDIlluminated configured for Wet Cell and **AGM*** batteries

2ND AMBER LEDIlluminated configured for Gel Cell batteries

1ST RED LEDCharging - Initial Charging Up To 30%

2ND & 3RD RED LEDCharging - 60% Complete

1ST, 2ND & 3RD RED LEDCharging - 90% Complete

BLINKING GREEN LEDFinishing Stage (Note: Battery Type Indicator will also blink during this stage)

STEADY GREEN LEDCharge Complete –

.....Float/Maintenance Mode-On for 5 min. and off for 60 min.

The green LED is illuminated whenever the charge cycle has terminated and the internal circuitry has determined the batteries to be fully charged. The green LED will blink during the finishing stage of the charge cycle. After the completion of the charge cycle, the green LED will remain on steady during the float-maintenance stage.

During this final stage current is only flowing to the battery system for 5 minutes and then current will stop completely for 60 minutes. Your system provides an equalization stage every 30 days while plugged in. If the charger is normally disconnected from A/C after completing charge, equalization can be accomplished by plugging back into A/C whenever this stage is desired. Battery manufacturers recommend that equalization is done once a month in order to further reduce sulfation on the lead plates of a battery, which helps promote longer battery life.

NOTICE : During this process the LEDs will go through their normal routine (Red LEDs counting up for % of charge along with the illuminated Red LED Battery Type and then the Green LED and Red Battery Type LED will blink) until the unit returns to the maintenance mode and a steady Green LED and steady Red Battery Type LED. (Not applicable to Gel Profile).

4.7.1 TROUBLESHOOTING

PROBLEM: No LED indicators illuminated on battery status indicator.

Solution Sequence:

1. Confirm that current is being delivered to the charger. Use a meter or test light to check the AC power supply from its source through all connecting points up to the charger.
2. Check that the AC circuit breaker (on front of the unit) is depressed.
3. Call ParCar technical support for further assistance.

PROBLEM: The charge status indicator changes rapidly back and forth from red to green or the green LED will not illuminate after excessive charging time (24 hours or more).

Solution Sequence:

1. Disconnect AC power from the charging system. This indication may signify a possible battery problem.
2. Call ParCar technical support for further assistance.

PROBLEM: A green LED was illuminated before disconnecting the power from the charger, but upon reconnection, red LEDs appear and remain on.

This is the normal operating procedure for the system. It indicates that a reanalysis of the battery status was initiated and after a series of steps the green LED will illuminate.

4.7.2 LIGHT EMITTING DIODES (LED) FAULT CODE INDICATIONS

The microprocessor is constantly monitoring the charger circuitry and will both detect and display blinking LED indications if a fault is detected. The battery type LED will be **OFF** during a fault code condition.

30% RED LED BLINKINGNO BATTERY DETECTED

This indication occurs whenever the charger circuitry cannot detect a battery. The charger circuitry will not allow charge current to flow under this condition. With the AC power supply cord unplugged, check the connection to the batteries for proper polarity (black wire to negative or -). Also check for corrosion free secure connections to the battery.

30 & 60% RED LEDS BLINKINGFORMING STAGE TIMEOUT SHUTDOWN

This indication occurs if the battery voltage has not risen above 1.75 volts per cell within the first 3 hours of charging. This indicates that a possible battery problem exists and that the charge cycle has been terminated at this point.

30, 60 & 90% RED LEDS BLINKING.....OVERALL TIMER SHUTDOWN

This indication occurs if the charger has not completed the charge cycle within the allowable factory set time period. This indicates that a possible battery problem exists and that the charge cycle has been terminated at this point.

30 & 90% RED LEDS BLINKINGINTERNAL OVERTEMP SHUTDOWN

This indication occurs if the charger circuitry has detected operating temperatures inside the charger enclosure that are above factory specified levels. This could indicate that a possible charger problem exists and that the charge cycle has been terminated.

30% RED & 100% GREEN LEDS BLINKING BULK STAGE SHUTDOWN

This indication occurs if the battery voltage does not rise properly during the Bulk Stage. This indicates that a possible battery problem exists and that the charge cycle has been terminated at this point. Please call ParCar technical support for further assistance.

NOTICE: Disconnecting and reconnecting the AC power supply cord will reset the charger.

4.8 EXCESSIVELY DISCHARGED BATTERIES

NOTICE: Columbia Dealer will have the equipment and experience to perform the following battery inspections.

The charger will not charge dead batteries. First establish that none of the batteries have an internal fault or bad cell. If a battery has remained too long in a discharged state (i.e. 2-4 volts each), it may be internally damaged and not capable of accepting a charge and must be replaced.

If the electrolyte Specific Gravity is low (less than 1.1098 SG) or individual battery voltage is less than 5.25 volts for three cells (10.5 volts for six cells), recharge each battery with an ordinary automotive style trickle charger at a rate of 3 to 6 amps.

It is not necessary to disconnect the battery cables, as the alligator style clips can be connected to each positive and negative battery post. Follow specific charger instructions.

▲ DANGER
To prevent a spark from igniting the gas emitted from the batteries, always disconnect the Charger AC power cord first when moving the positive/negative alligator clips.

Be sure to charge all of the batteries in the set. Each battery may require two to three hours of charging to bring it back to serviceable condition. After all batteries have been individually charged, remove the automotive Charger and restart charging with the charger. If again the charger has the RED FAULT LED) flashing there is a problem with one or more of the batteries.

4.9 SPECIFIC GRAVITY TEST

It is possible to determine a battery's ability to perform by measuring the specific gravity (sp. gr.) of each cell with a hydrometer. This is the best method to determine a defective battery.

The hydrometer readings indicate two things:

- State of Charge - The amount of electrical power stored in the battery.
- Condition - The ability of battery to store and deliver power.

NOTICE: Batteries should be fully charged before performing specific gravity tests to determine battery condition. Hydrometer tests of batteries not fully charged are misleading and inconclusive.

There are different type hydrometers. Carefully read and follow the instructions supplied with your hydrometer.

NOTICE: Specific gravity readings are at 80°F. Values need adjustment for electrolyte temperature. Reduce .004 for every 10°F below 80°F. Increase by that amount for every 10°F above.

4.10 TIPS FOR PROLONGING BATTERY LIFE

NOTICE: A common misconception is Deep Cycle Batteries develop a memory, lose capacity, or must be discharged until the BDI warning flashes and then recharged. Deep Cycle Wet Lead Acid Batteries are not like cell phone NiCad Batteries. Deep Cycle Batteries benefit from frequent charging and being maintained at as close as possible to a 100% state of charge. Plugging in the charger overnight or when the vehicle is not in use for 3-5 or more days is encouraged.

- Recharge batteries as soon as they become 20% or more discharged (less than 1.238 sp. gr.).
- Make it a regular habit to plug in the charger when the vehicle is not in use. Batteries may be recharged if vehicle has been driven 15 minutes or more since the previous charge.
- Make sure your electrical outlet is operational.
- Never go below 20% state of charge (or 80% discharged) without recharging immediately. Allow 14 – 16 hours of charging.
- Batteries will provide a longer life if not deeply discharged. Batteries that are regularly deeply discharged will require more work by the charger and will have a shorter life.
- Make it a regular habit to check (and water) your batteries after charging. Always add water after charging. This will reduce the chance for overflow due to expanding water.
- Weekly equalize the battery pack.
- If the vehicle is not operated daily the Power keyswitch should be turned off. This will power down the traction control system and reduces power loss on the batteries.
- Batteries in storage may self discharge and should be recharged when the specific gravity falls below 1.238 sp. gr.

4.11 BATTERY REMOVAL & INSTALLATION

- Remove battery negative (-) cables.
- Remove battery positive (+) cables.
- Remove battery hold down.
- Remove batteries from vehicle.
- To install batteries, reverse the removal procedure with the negative (-) cables being attached last.

4.12 SINGLE POINT BATTERY WATERING SYSTEM

When equipped, this is a single point watering system for maintaining a sufficient electrolyte level in the batteries.

NOTICE: Do not operate this system on brand new batteries. See Section 3.1 for the initial check on the electrolyte level of new batteries. Complete 4 to 5 charge cycles before using the system.

System is to be used only after fully charging the batteries and batteries are warm.

The fill tube assembly which is used for adding water to the battery pack consists of a fill tube, one end having a filter screen, the other having a female coupler and a rubber squeeze bulb.

Check the battery pack water level weekly by:

- Inserting the fill tube filter end in an approved water supply.
- Attaching the female coupler to the battery pack male coupler.
- Squeeze the rubber ball until firm which indicates that filling is complete. Immediately disconnect the couplers by depressing the push button on the female coupler. If the water supply is left connected after the filling process is finished it could lead to an overflow.

5.0 SERVICING YOUR VEHICLE

5.1 MAINTENANCE GUIDELINES

To ensure that the vehicle is kept in a safe and correct operating condition, it must be inspected and maintained on a regular basis. Proper lubrication, electrical control adjustments, safety feature checks, etc. performed at recommended intervals will help prevent damage or failure of the unit while providing optimum performance.

Follow the guidelines below to assure proper maintenance.

- Before starting any repairs or maintenance, immobilize the vehicle by turning the power keyswitch off, removing the key and setting the park brake.
- Disconnect both of the main battery pack leads before working on or disconnecting any electrical component or wire.
- Block the chassis with jack stands before working under a raised vehicle.
- Do not use flammable fluids for cleaning parts.
- Work in a properly ventilated work area.
- Regularly inspect and maintain in safe working condition the brakes, steering mechanisms, speed and directional control mechanisms, warning devices, guards and safety devices.
- Keep the vehicle in a clean condition to minimize fire hazards and facilitate detection of loose or defective parts.

5.2 MECHANICAL BRAKE SYSTEM

The mechanical brakes consist of two rear drum brakes which are self-adjusting. Monthly, with the vehicle stationary, depress the brake pedal and check for 1/4" pedal free travel before resistance is felt. Maximum pedal free travel should not exceed 2" measured from floor board to top of pedal See Figure 5.5.1

The parking brake is applied by depressing the parking brake pad at the top of the brake pedal which locks the brakes in place. If the brakes fail to hold the vehicle in position, contact your Columbia Dealer for qualified service assistance.

5.3 HYDRAULIC BRAKE SYSTEM

These vehicles are equipped with two rear wheel hydraulic brakes as standard or optional four wheel hydraulic brakes. Monthly, with the vehicle stationary, depress the brake pedal. See Figure 5.5.1. Pedal should not travel in excess of 2 1/2" as measured from floor board. If pedal travel in excess of 2 1/2" before resistance is felt or if pedal feel spongy or soft, contact your Columbia Dealer for qualified service assistance

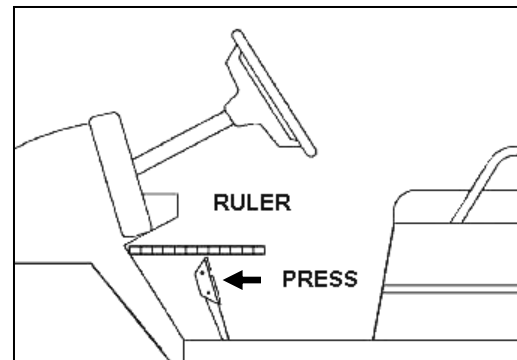

Figure 5.5.1

A hand operated (mechanical) parking brake is used on these vehicles. Monthly check the parking brake operation. Parking brake hand lever should travel no more than 3-1/2" upward when engaged. Check that ratchet mechanism automatically holds parking brake handle in the up position. Make sure the release button on the handle frees the parking brake lever and that the lever returns to full down (released) position. Contact your Columbia Dealer for qualified service assistance for problems with the parking brake or if the parking brake hand lever travels more than 3-1/2" upward.

▲ DANGER

If any of the listed limits are exceeded stop and do not use the vehicle. Contact your Columbia Dealer for qualified service assistance.

5.4 BRAKE FLUID MAINTENANCE

Check the brake fluid in the master cylinder periodically (under normal conditions, every 3 months). Use DOT 3 Motor Vehicle Brake fluid. Maintain fluid level within 1/4" of master cylinder filler opening.

5.5 TIRE CARE

See Sect 1.4 for recommended tire pressure. Improper inflation will shorten the life of your tires and will adversely affect performance. Do not exceed maximum stated on tire sidewall.

NOTICE: Replacement tires must be the same size as original equipment. Increased tire load ratings are permissible but tire rating does not increase the rated load carrying capacity of the vehicle.

5.6 WHEEL & TIRE REMOVAL/INSTALLATION

Place blocks ahead of and behind the wheels that will remain on ground. Slightly loosen lug nuts. Place a jack under the side of the vehicle in contact with the frame. Raise vehicle and remove lug nuts and wheels. To install, tighten the lug nuts evenly in a star pattern until the nuts are all seated and torque to 65 ft. lbs. (88.1 N.m). Recheck lug nut torque with the vehicle on the ground

NOTICE: The wheel may be bent if not torqued in a crossing pattern. This will cause the wheel to wobble

5.7 CLEANING

Wash underside to remove all dirt and debris. Do not direct high pressure water at the controller, speed switches, or tops of the batteries.

Wash body and seat with a mild detergent. Do not use abrasives (bodies are painted). Frequent washings with mild soap will preserve the finish of your vehicle. For stubborn and imbedded dirt, a soft bristle brush may be used. Tar, asphalt, creosote and the like should be removed immediately to prevent staining of paint.

NOTICE: Do not use harsh detergents, abrasives or cleaning solvents that contain ammonia, aromatic solvents or alkaline material to clean cab.

5.8 LUBRICATION

Every 6 months apply light oil to the rear body hinges.

Semi-annually grease the vehicle chassis. There are seven fittings: three on each side of the front suspension and one on the brake pedal pivot. Use a high quality grease. Remove the weight from the front suspension before lubricating to ensure proper grease distribution.

The differential should be checked periodically for signs of leakage. Contact your Columbia Dealer for fluid replacement.

5.9 MAINTENANCE SCHEDULE - OWNER/OPERATOR

Item	Operation	Weekly	Monthly	Semi-Annual
Tires	Lug nuts tight.		*	
	Check tire pressure, wear, damage. dented rims.		*	
Electrical	Check electrolyte level.	*		
	Apply equalization charge to the battery pack.	*		
	As required, clean battery terminals and wash cases.	*		
	Check the general condition of the electrical system (connections, frayed/broken cables).		*	
Brakes	Check pedal & park brake operation.		*	
Body and Frame	Inspect for loose hardware (bolts & nuts).	*		
	Clean body and seats, Wash as needed.	*		
	Wash engine compartment and undercarriage.	*		
Lube	Visual check for differential leak.		*	
	Oil movement points (body hinges, brake mechanisms and linkage, leaf spring bushings etc.).			*
Single Point Watering System	Add water per Section 4.12.	*		
	Check condition of tubing, couplers. Secure & leak free.		*	
	Clean filter screen.			*

5.10 MAINTENANCE SCHEDULE QUALIFIED TECHNICIAN

It is recommended that the following be performed by a trained qualified technician or your Columbia Dealer

Item	Operation	Quarterly	Semi-Annual	Annual
Tires	Front wheel alignment and camber.		*	
Electrical	Test batteries.		*	
	Inspect motor condition and operation.			*
Brakes	Check brakes, clean, adjust, replace if needed.		*	
	Check brake fluid (when equipped)	*		
Lube	Check differential fluid level.			*
	Grease fittings.		*	
Wheel	Check wheel axle nuts for tightness & torque.		*	
	When equipped,- wheel bearings, repack, replace if needed			*
Accelerator	Check micro switch adjustment, if equipped.		*	

5.11 VEHICLE TROUBLESHOOTING

PROBLEM	CHECK
Will not move	Power keyswitch on. Direction Selector in desired direction. Keyswitch for loose wires or faulty switch.
	Batteries for loose terminals, corrosion, electrolyte level or state of charge.
	Motor for loose wires, open circuits or worn brushes.
Will not move with power keyswitch is on and the direction Selector is in the desired direction	Controller green light. See Section 5.12
Runs slow	Batteries for loose terminals, corrosion, electrolyte level or state of charge.
	Brakes dragging
	Under inflated or flat tires.
	Wheels for binding, do not spin freely.
If these test procedures do not resolve your vehicle problem, contact your Columbia Dealer for service.	

5.12 CONTROLLER TROUBLESHOOTING

The controller is located under the rear body. See Figure 5.12.1. The controller has a green LED diagnostic light (Arrow Figure 5.12.1) which is a good tool to indicate a fault in the electrical system.

If the vehicle is equipped with a dash System Status LED, it functions the same as the controller LED.

It is essential to observe the flashing pattern (number of blinks followed by a pause) of the LED light any time the vehicle is not operating as expected. The number of blinks is very useful for your servicing dealer to accurately and quickly diagnose any faults that exist.

However, two of the flash codes may indicate an operation fault, and likely do not require component changes or dealer service.

A “2 Flash fault” may indicate a start-up sequence fault. This is caused when the vehicle direction Selector is not in the neutral position when the power keyswitch is turned on. Steps to take to possibly clear this fault are:

- Set the parking brake.
- Turn vehicle power keyswitch to OFF.
- Set direction Selector to N – Neutral.
- Ensure the accelerator pedal is at its resting (up) position.

- Turn vehicle power keyswitch to ON.
- Select the desired direction on the direction Selector.
- Release parking brake and depress accelerator.

A "7 flash fault" may indicate that the battery voltage is too high or too low for the vehicle power system. Voltage too high occurs when rapidly descending hills with a vehicle equipped with the ACE*plus* Regenerative braking system. The electrical system creates current which causes a spike in battery voltage. To prevent this, always travel at a safe, prudent speed when driving on declines, especially with freshly charged batteries. To possibly clear this fault turn the power keyswitch to OFF and back to ON. If there is still a “7 flash fault”, the battery voltage may be low. Check and charge batteries or replace batteries.

If the operational fault persists or the LED is not lit or there is a “flash fault” other than 2 or 7, contact your Columbia ParCar Dealer.

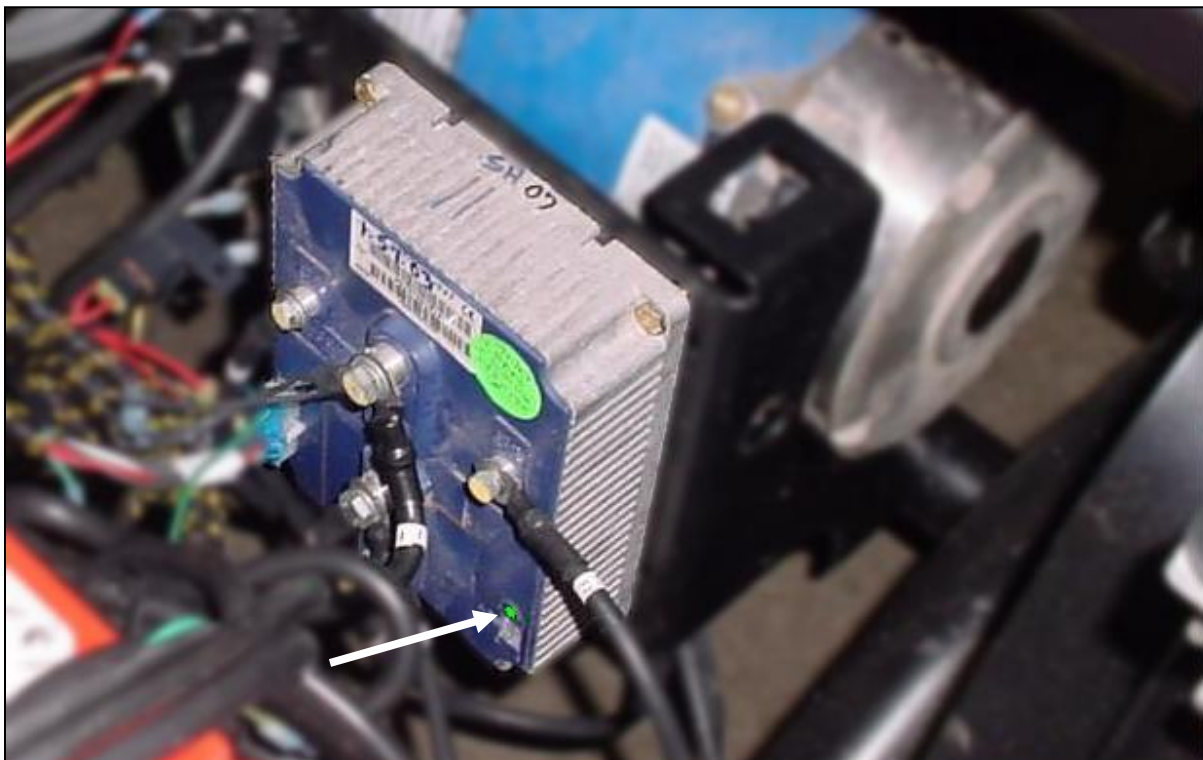

Figure 5.12.1

6.0 TOWING & TRANSPORTING

6.1 TOWING YOUR VEHICLE

NOTICE: Columbia ParCar does not recommend towing this vehicle.

6.2 TRANSPORTING YOUR VEHICLE

NOTICE: Never tow a vehicle behind an auto or truck unless on an approved trailer.

When trailering your vehicle over long distances or on the highway observe the following:

- Use trailers specifically designed to carry your Columbia ParCar vehicle that meets all federal, state and local requirements.
- Secure vehicle to the trailer following trailer manufacturer's instruction.
- The key should be removed from the vehicle, the parking brake firmly locked, and the wheels blocked.
- On vehicles equipped with high or wide additions or accessories be certain they are secured properly to prevent loss or damage while trailering.

7.0 VEHICLE STORAGE (over 6 weeks)

7.1 BATTERY PREPARATION

Before storage make sure batteries are fully charged and the electrolyte is full in all cells per Section 4.2. Clean the batteries and connections per Section 4.3.

The Delta-Q charger has the capability to test and recharge batteries during storage. Leave the batteries connected and the Delta-Q charger plugged into a reliable AC source.

If the Delta-Q is not used:

- Batteries will "self-discharge" during storage and recharging will be necessary. Frequency for recharging is as follows:

STORAGE TEMPERATURE	CHARGE AT
Below 4 ⁰ C (40 ⁰ F)	Every 6 months
4 ⁰ C - 16 ⁰ C (40 ⁰ – 60 ⁰ F)	Every 2 months
Above 16 ⁰ C (60 ⁰ F)	Once a month

- The specific gravity of the electrolyte should be checked every 6 to 8 weeks using a hydrometer. See Section 4.7 for further details.
- The batteries should be recharged to a specific gravity of approximately 1.260 sp. gr.
- After charging, disconnect the batteries. See Section 2.4.

▲ DANGER

Batteries in a low state of charge will freeze at higher temperatures than fully charged batteries. Do not attempt to charge a battery that is frozen or if battery case is excessively bulged. Properly dispose of battery, because frozen batteries can explode.

Table B indicates freezing points of batteries at different specific gravities.

TABLE B	
SPECIFIC GRAVITY	FREEZE POINT ⁰ F/ ⁰ C
1.260	-70/-57
1.230	-39/-38
1.200	-16/-26
1.117	-2/-19
1.110	+17/-8

NOTICE: Specific gravity readings are at 80⁰F. Values need adjustment for electrolyte temperature. Reduce .004 for every 10⁰F below 80⁰F. Increase by that amount for every 10⁰F above

For vehicles with a single point watering system, quarterly during storage check water levels per Section 4.10.

7.2 VEHICLE PREPARATION

- Store the vehicle in a cool place.
- Maintain tire pressure. See Section 1.4.
- Grease suspension and continue quarterly lubrication during storage period.
- Clean vehicle body, seats, battery compartment and vehicle underside.
- Do not engage park brake. Block wheels to prevent movement.

NOTICE: Make sure power keyswitch is in the OFF position.

7.3 RETURNING VEHICLE TO SERVICE

- If necessary, connect the battery pack and fully recharge batteries.
- Check tire pressure and readjust if necessary. See Section 1.4.
- Perform initial maintenance per Section 3.6.

For vehicles with a single point watering system:

- After the batteries have been fully charged, connect the system to its water supply for 3-5 seconds then disconnect regardless of whether or not the batteries are completely full.
- Return the vehicle to its regular service.
- Place the vehicle back into its regular watering schedule (waiting at least 1 week until next watering).



1115 Commercial Avenue • Reedsburg, WI 53959
Phone: (608) 524-8888 • (800) 222-4653 • Web: www.parcars.com